

# JAGUAR XF SALOON AND NEW XF SPORTBRAKE



THE ART OF PERFORMANCE









BY APPOINTMENT TO  
HM THE QUEEN  
MANUFACTURERS OF  
MOTOR VEHICLES  
JAGUAR LAND ROVER LIMITED  
COVENTRY



BY APPOINTMENT TO  
HRH THE DUKE OF EDINBURGH  
MANUFACTURERS OF  
MOTOR VEHICLES  
JAGUAR LAND ROVER LIMITED  
COVENTRY



BY APPOINTMENT TO  
HRH THE PRINCE OF WALES  
MANUFACTURERS OF  
MOTOR VEHICLES  
JAGUAR LAND ROVER LIMITED  
COVENTRY



JAGUAR

## THE ART OF PERFORMANCE

Every day we push performance to its limit. Our performance. Our cars' performance.  
We innovate, we engineer, we design. We master rules and then break them.  
Only to push further. Past the limits of convention. This is when performance becomes art.

Jaguar. The Art of Performance.









## CONTENTS

### INTRODUCTION

The Concept of XF	06
XF - The Facts	08

### DESIGN

Exterior Principles	10
Exterior Aerodynamics	12
Interior	15
Interior Space	17
Space and Versatility	19

### PERFORMANCE

Engines Overview	22
Advanced Aerodynamics	26
Lightweight Aluminium Architecture	29
Chassis and Suspension	30

### DRIVING TECHNOLOGY

Advanced Driving Dynamics	32
Added Driver Confidence	34
Advanced Drivetrain Technology	37
Torque Vectoring	39
Stability and Control	41
Head-up Display	43

### INCONTROL TECHNOLOGIES

Infotainment and Connectivity	44
Touch and Connect	47
Touch Pro and Connect Pro	49
Audio	50

### SAFETY

Advanced Driver Assistance	52
----------------------------	----

### PERSONALISATION

XF - Your Choice	54
Choose your Engine	56
Choose your Model	60
Choose your Colour	62
Choose your Wheels	64
Choose your Interior	66
Choose your Jaguar Gear	84
Technical Specifications	92
Dimensions	96

### JAGUAR WORLD

Jaguar Experience	100
The World of Jaguar	102
Glossary and Legal Information	104



Scan to find out more about the Jaguar XF.

VEHICLES SHOWN: XF SPORTBRAKE S IN YULONG WHITE AND XF SALOON R-SPORT IN CORRIS GREY WITH OPTIONAL FEATURES FITTED (MARKET DEPENDENT)

VEHICLES SHOWN ARE FROM THE JAGUAR GLOBAL RANGE. SPECIFICATIONS, OPTIONS AND AVAILABILITY WILL VARY BETWEEN MARKETS AND SHOULD BE VERIFIED WITH YOUR LOCAL JAGUAR RETAILER









## INTRODUCTION

# THE CONCEPT OF XF

XF builds on the success of Jaguar's most award-winning car ever. Possessing an unrivalled combination of style and substance, it delivers an utterly seductive blend of design, dynamics and refinement to create a car that offers both excitement and efficiency. All enhanced by state-of-the-art technologies that help keep you safe, connected and entertained.

XF sits in the Jaguar range between XE's taut athleticism and the supreme luxury of XJ. The fusion of these outstanding Jaguar attributes is what creates XF - the most dynamic, premium business car of its generation. New XF Sportbrake complements XF Saloon's distinctive 'coupé' lines and dynamism with even greater space and versatility.

Standard and optional features may differ depending on market availability.  
Please consult your local Jaguar Retailer for details.

**VEHICLES SHOWN: XF SPORTBRAKE S IN YULONG WHITE AND XF SALOON R-SPORT IN CORRIS GREY WITH OPTIONAL FEATURES FITTED (MARKET DEPENDENT)**





# XF - THE FACTS

An outstanding combination of advanced engineering, the latest technology and contemporary design sets XF apart.

## EFFICIENCY AND PERFORMANCE

Find your perfect balance of economy and power in the XF Saloon and Sportbrake engine range. Many engines feature our Ingenium technology, including the 2.0 litre 4 cylinder 163PS Turbocharged Diesel that can achieve CO<sub>2</sub> emissions as low as 104g/km<sup>††</sup> and economy up to 4.0 l/100km (70.6mpg)<sup>††</sup>. XF's most powerful engine, the 3.0 litre V6 380PS Supercharged<sup>‡</sup>, can sprint from 0-100km in 5.3 seconds<sup>††</sup> and reach a top speed of 250km/h (155mph).

## REAR AIR SUSPENSION

Even when fully loaded, XF Sportbrake's comfort and precise handling is maintained by self-levelling rear air suspension. This system automatically inflates air springs to counteract the weight of heavy loads, this helps ensure a level chassis and ride height.

\*XF Saloon only. Drag coefficient for XF Sportbrake is Cd 0.29.

\*\*40:20:40 split fold rear seats are standard on XF Sportbrake.

†Feature only available as part of Touch Pro.

††Engine performance and efficiency figures representative of XF Saloon only.

‡Only available on XF Saloon.

For detailed XF Saloon and Sportbrake technical specifications, see pages 92 to 95.

Standard and optional features may differ depending on market availability. Please consult your local Jaguar Retailer for details.

**VEHICLES SHOWN: XF SPORTBRAKE S IN YULONG WHITE AND XF SALOON R-SPORT IN CORRIS GREY WITH OPTIONAL FEATURES FITTED (MARKET DEPENDENT)**

## DYNAMIC DESIGN

With a sleek, low swooping roofline and optional 1.6m<sup>2</sup> panoramic glass roof, XF Sportbrake makes no compromise between assertive style and versatility. Perfectly executed to carry more, its proportions have been shaped to achieve aerodynamic excellence.



## ADDED INTELLIGENCE

Innovative technologies make every drive easier and safer. XF offers Adaptive LED headlights, Traffic Sign Recognition with Adaptive Speed Limiter, Lane Keep Assist with Driver Condition Monitor, Autonomous Emergency Braking, Adaptive Cruise Control with Queue Assist, Park Assist and Blind Spot Assist. With Powered Gesture Boot Lid you can access the boot when your hands are full. Simply present your foot under either rear corner and the boot opens or closes.



## **CRAFTSMANSHIP AND SPACE**

Contemporary craftsmanship and a luxurious, practical interior with the space to stretch out and enjoy every journey. Your front and rear passengers will appreciate leg, knee and headroom that are among the best in class. You can choose the optional 40:20:40 rear seating\*\* configuration for increased volume and versatility.

## **CONNECTIVITY**

Every drive in XF is enhanced by InControl technologies. InControl is a suite of products and services that connects you with your XF and links XF to the wider world. It ensures you are always in touch. With the option of Dual View†, front passenger and driver can enjoy different media on the same Touchscreen.

## **LIGHTWEIGHT ALUMINIUM ARCHITECTURE**

XF's Lightweight Aluminium Architecture creates an incredibly strong body that delivers precise and responsive sports handling with impressive fuel efficiency.

## **ADVANCED DRIVETRAIN TECHNOLOGY**

XF offers Jaguar's unique All Wheel Drive with Intelligent Driveline Dynamics (IDD) and Adaptive Surface Response (AdSR) on both petrol and diesel models. This maximises the legendary Jaguar handling, agility and ride, and gives added confidence in all conditions.

## **ADVANCED AERODYNAMICS**

XF is capable of achieving a drag coefficient of just Cd 0.26\*. Even the underside of the car is aerodynamically designed to be as smooth as possible, while apertures in the front bumper optimise airflow through the wheel arches. XF cuts through the air, reducing wind noise for enhanced refinement and improved efficiency.







## DESIGN EXTERIOR PRINCIPLES



DESIGN PURITY

ADAPTIVE LED HEADLIGHTS

"It's about paring it down to the bare essentials. Good designers have always said less is more."  
Ian Callum, Jaguar Design Director.

XF demonstrates the Jaguar principles of design purity. Strong lines radiate dynamic character and enhance its capabilities – be it improving aerodynamics, visibility, stability or safety. XF is available with adaptive LED headlights\* featuring Jaguar signature 'J' blade Daytime Running Lights to give XF a striking on road presence. The quality of LED light is close to daylight, helping your eyes to distinguish objects more easily and reducing fatigue at night.

\*Optional feature, Xenon or Halogen headlights are also available depending on the model chosen.

VEHICLE SHOWN RIGHT: XF SALOON R-SPORT IN CORRIS GREY WITH OPTIONAL FEATURES FITTED (MARKET DEPENDENT)





776 XCN



# EXTERIOR AERODYNAMICS



AERODYNAMIC DESIGN

F-TYPE INSPIRED DESIGN

XF's sweeping exterior design is naturally aerodynamic. Its advanced form enhances handling, dynamics and refinement. Airflow is carefully managed through and around the car. Intakes either side of the front grille draw air in, then channel it out from the wheel arches to reduce turbulence. As air flows along the car, pressure differences that can cause drag are minimised by the flush, aerodynamically optimised sides.





At the rear, XF's tail lights feature a distinctive, F-TYPE inspired roundel and intersecting horizontal detail. The LED brake lights are not only brighter than halogen bulbs, they use less energy - contributing to XF's overall drive for greater efficiency. LEDs also illuminate faster - so following drivers can react more quickly to XF's braking. Within the tail lights is a pinstripe graphic - one of XF's many exquisite finishing touches.

VEHICLES SHOWN: XF SPORTBRAKE S IN YULONG WHITE AND XF SALOON R-SPORT IN CORRIS GREY WITH OPTIONAL FEATURES FITTED (MARKET DEPENDENT)







HOME 17:06

Darkness Oliver Galtby Darkness 6/12	23°C Outside: FOX 21°C
David S. Miller Lullaby	High SE Kensington

Navigation icons: Home, Search, Phone, Navigation, Music, App Store, Google Play, CarPlay, Android Auto.

SYNC, MAX, MAX A/C, A/C, AUTO

Start/Stop button, Engine Start/Stop button

PRND

Drive mode selector: Park, Reverse, Neutral, Drive, Sport





## INTERIOR



**DRAMATIC START-UP  
SEQUENCE**

**CONTEMPORARY  
CRAFTSMANSHIP**

Open XF's door and the Start button entices you inside. Pulsing with a heartbeat it creates an emotional connection between driver and machine. Its 72 per minute double beat is the same as a jaguar cat at rest. XF is poised, ready for action. Now push the Start button. The car awakens and its mood lighting illuminates. With perfect choreography, air vents rotate open, the JaguarDrive Selector rises smoothly, and the engine growls - all inspiring you to anticipate the drive ahead.

XF's interior offers outstanding comfort, a sense of wellbeing and a wealth of choice. The number of switches and buttons is kept to a minimum to keep the look clean and tidy, as well as making them easy to use. Whichever XF interior combination you choose, materials used are always of the highest quality. Leather and finishes are selected with the greatest care to ensure that, inside XF, everything is luxurious to the touch. Whether you prefer aluminium, carbon fibre, or wood veneer finishes to complement the beautiful selection of leathers, your XF will always look and feel just right.

To enhance the cabin's sense of wellbeing, XF Sportbrake offers a new ionisation system that improves air quality. With this optional system, air is passed through an ioniser that filters and purifies the airflow before it is circulated within the cabin. This neutralises odours as well as minimising bacteria and pollution for a more pleasant and healthy in-car environment.

INTERIOR SHOWN: XF SALOON S FEATURING LIGHT OYSTER/EBONY SEATS WITH EBONY UPPER FACIA WITH CONTRAST STITCH, EBONY CARPET AND EBONY HEADLINING WITH OPTIONAL FEATURES FITTED (MARKET DEPENDENT)









1. Headroom 970mm (994mm\* on XF Sportbrake) 2. Knee room 87mm

## INTERIOR SPACE



GENEROUS REAR SPACE

IMPRESSIVE VERSATILITY

In both XF Saloon and Sportbrake, the rear of the cabin is a destination of luxury, choice and space. The generous rear knee room is among the best in class, while the ample rear legroom and rear headroom give you room to relax. It all adds up to greater comfort and well-being for passengers.

Interior mood lighting also enhances XF's atmosphere. Opt for Configurable Interior Mood Lighting and you'll have a choice of ten interior colours. The choice continues with optional Four-zone Climate Control, giving individual passengers the opportunity to set their own temperature and airflow.

At 540 litres, the loadspace of XF Saloon offers plenty of carrying capacity. For even greater versatility, choose the optional 40:20:40 rear seating configuration - it increases loadspace to an impressive 885 litres. This outstanding practicality is taken to the next level in XF Sportbrake.

\*1,020mm with optional fixed panoramic roof on XF Sportbrake.

Standard and optional features may differ depending on market availability. Please consult your local Jaguar Retailer for details.

INTERIOR SHOWN: XF SALOON S FEATURING LIGHT OYSTER/EBONY SEATS WITH EBONY UPPER FACIA WITH CONTRAST STITCH, EBONY CARPET AND EBONY HEADLINING WITH OPTIONAL FEATURES FITTED (MARKET DEPENDENT)







## SPACE AND VERSATILITY



SUBSTANTIAL LOADSPACE

ACTIVITY KEY

XF Sportbrake's versatile interior is designed to meet the demands of your lifestyle. Its loadspace provides 565 litres of space with the rear seats in place. Fold the rear seats down, and you'll create a space that is two metres in length and over a metre in width at its narrowest point, featuring 1,700 litres of luggage capacity plus discreet underfloor stowage.

To make everything that bit easier, XF Sportbrake offers a powered tailgate as standard, and a Powered Gesture Tailgate and Activity Key as options. Activity Key is a robust and fully waterproof wristband that allows you to enjoy a range of activities - from skydiving to swimming - while giving you immediate access to the car at all times. The conventional key fob can remain within the car as it is deactivated for security purposes.

Standard and optional features may differ depending on market availability. Please consult your local Jaguar Retailer for details.

INTERIOR SHOWN: XF SPORTBRAKE S FEATURING BROGUE SEATS WITH CONTRAST STITCH, EBONY CARPET AND EBONY HEADLINING WITH OPTIONAL FEATURES FITTED (MARKET DEPENDENT)











#### 40:20:40 SPLIT FOLD SEATS

#### FIXED PANORAMIC ROOF

XF Sportbrake's rear seats fold completely flat or can be divided with a 40:20:40 split, using a thoughtfully placed remote release that's accessible from the tailgate area. Easy-to-use loadspace rails help further increase the adaptability of loadspace stowage, and a divider net prevents objects from falling onto the rear seats.

Introducing even more natural light and airiness to the interior, XF Sportbrake's optional 1.6m<sup>2</sup> fixed panoramic roof is the largest in its class. There's also the option of a gesture roof blind that can be opened and closed with a simple swipe of your hand without you ever having to take your eyes off the road.

Standard and optional features may differ depending on market availability. Please consult your local Jaguar Retailer for details.

INTERIOR SHOWN: XF SPORTBRAKE S FEATURING BROGUE SEATS WITH CONTRAST STITCH, EBONY CARPET AND EBONY HEADLINING WITH OPTIONAL FEATURES FITTED (MARKET DEPENDENT)



## PERFORMANCE ENGINES OVERVIEW



INGENIUM ENGINES

STOP/START TECHNOLOGY\*

Ingenium technology underpins three of the diesel engines in the XF range. These low friction, all-aluminium engines have stiff cylinder blocks and twin balancer shafts to ensure inherently low levels of vibration, for smooth day-to-day performance. All engines are equipped with Stop/Start technology\* and smart regenerative charging - harvesting kinetic energy from braking to charge the battery - for maximum economy, especially during urban driving. XF's diesel engines are available with either a 6-speed Manual Transmission that provides slick, short changes or an 8-speed Automatic Transmission that is highly responsive, smooth and efficient. For information on transmission availability, fuel consumption, CO<sub>2</sub> emissions and performance figures for XF's engines, please refer to pages 92 to 95.



AdBlue®

INGENIUM DIESEL ENGINES FROM

104g/km\*\* CO<sub>2</sub>

The **Ingenium 2.0 litre 4 cylinder 163PS Turbocharged Diesel** is refined and highly efficient. Low-flow direct injectors precisely control the amount of fuel that enters the combustion chamber for maximum efficiency. Intelligent, electronically controlled, adaptive engine cooling only engages when required - minimising fuel consumption and CO<sub>2</sub> emissions. This doesn't limit driving pleasure, the engine's strong torque gives good performance from low down in the rev range for brisk acceleration.

The **Ingenium 2.0 litre 4 cylinder 180PS Turbocharged Diesel** offers impressive performance and economy. For an engine of this size it offers high levels of torque, but not at the expense of efficiency - a balance achieved thanks to its variable geometry turbocharger. Adapting to the changing flow of exhaust gases, it maximises low speed torque for broad power and responsiveness that is uniform, progressive and avoids lag.

The **Ingenium 2.0 litre 4 cylinder 240PS Twin Turbocharged Diesel** delivers high power and torque. Its series sequential twin turbocharger uses high and low pressure spools to give continuous acceleration and maximise performance. A higher specific power output is created by building on Ingenium technology. Upgrades include a higher pressure common rail fuel system, increased from 1,800 to 2,200 bar, and an improved fuel injector flow rate.

\*Market dependent. \*\*Engine performance and efficiency figures representative of XF Saloon only. For detailed XF Saloon and Sportbrake technical specifications, see pages 92 to 95.

Engine availability is market dependent.  
Please consult your local Jaguar Retailer for details.





AdBlue®

DIESEL ENGINE

0-100km/h in 6.2 seconds\*\*

The **3.0 litre V6 300PS Twin Turbocharged Diesel** engine offers exceptional power, torque and drivability. It uses innovative twin-parallel sequential turbocharging – a concept pioneered by Jaguar Land Rover – for smooth, more immediate delivery of power at all engine speeds, as well as two-stage water cooling to conserve energy.



XF offers a choice of petrol engines, including three from our Ingenium range. With their lightweight, all-aluminium design, and widespread use of low-friction roller bearings, Ingenium petrol engines are built for smooth, highly efficient performance. To guarantee a responsive drive and effortless acceleration, every XF petrol engine makes use of a rapid-shifting, 8-speed Automatic Transmission. All engines are equipped with Stop/Start technology\* and smart regenerative charging – harvesting kinetic energy from braking to charge the battery – for maximum economy, especially during urban driving. For information on transmission availability, fuel consumption, CO<sub>2</sub> emissions and performance figures for XF's engines, please refer to pages 92 to 95.



INGENIUM PETROL ENGINES UP TO

**0-100km/h in 5.8 seconds\*\***

The **Ingenium 2.0 litre 4 cylinder 200PS Turbocharged Petrol†** engine offers the drivability of larger engines, but with much lower fuel consumption. Direct fuel injection from centrally mounted solenoid injectors ensures precise delivery of fuel for highly efficient and clean combustion. Intelligent Continuously Variable Valve Lift control manages early or late opening of inlet valves, meaning the engine can adapt its performance to all driving situations. This works with dual independent variable cam timing to optimise power at all speeds.

The **Ingenium 2.0 litre 4 cylinder 250PS Turbocharged Petrol** engine delivers outstanding usable power and torque. For excellent acceleration and effortless overtaking, maximum torque is available between 1,300-4,500 rpm. This engine's twin scroll turbocharger is fed by an integrated exhaust manifold that synchronises exhaust pulses from two separate pairs of cylinders – significantly reducing turbo lag and improving engine response.

The **Ingenium 2.0 litre 4 cylinder 300PS Turbocharged Petrol†** engine's impressive power is balanced with strong fuel economy. For almost instant boost and high efficiency, its low inertia twin-scroll turbocharger features low-friction ball bearings and a high flow compressor wheel. Underpinned by the turbocharger's increased aerodynamic efficiency, the engine delivers rapid acceleration and maximum torque of 400Nm between 1,500-4,500rpm.

\*Market dependent. \*\*Engine performance and efficiency figures representative of XF Saloon only. For detailed XF Saloon and Sportbrake technical specifications, see pages 92 to 95.

†Only available on XF Saloon.

Engine availability is market dependent.  
Please consult your local Jaguar Retailer for details.





PETROL ENGINE UP TO

**0-100km/h in 5.3 seconds\*\***

The **3.0 litre V6 380PS Supercharged Petrol engine\*\*** features a Roots-type twin vortex supercharger that provides linear delivery of power and maximises responsiveness. This results in performance matching much larger engines, while optimising economy and reducing emissions. The engine also features dual independent variable cam timing to vary inlet and exhaust valve operation, working alongside lightweight pistons with ultra-low friction piston rings, for increased performance and efficiency. For added refinement there is a twin, contra-rotating balancer shaft system.



## ADVANCED AERODYNAMICS



LOW DRAG

| CD 0.26\*

XF's form has been rigorously optimised for aerodynamic efficiency and stability at motorway speeds. With a drag coefficient as low as Cd 0.26\*, XF cuts through the air - reducing fuel consumption and lowering emissions. Every element exploits the exterior's maximum aerodynamic potential while preserving XF's stunning proportions. Vertical apertures in the front bumper outer edges channel air through vents in the wheel arches and out over the front wheels. The airflow then passes along XF's sides where the doors have a flatter cross sectional profile to minimise air pressure differences and contribute further to reduced drag. Even the extensive under body protection is designed to make XF as efficient, economical and refined as possible.

\*XF Saloon only. Drag coefficient for XF Sportbrake is Cd 0.29.

VEHICLE SHOWN: XF SALOON PORTFOLIO IN SANTORINI BLACK WITH OPTIONAL FEATURES FITTED (MARKET DEPENDENT)





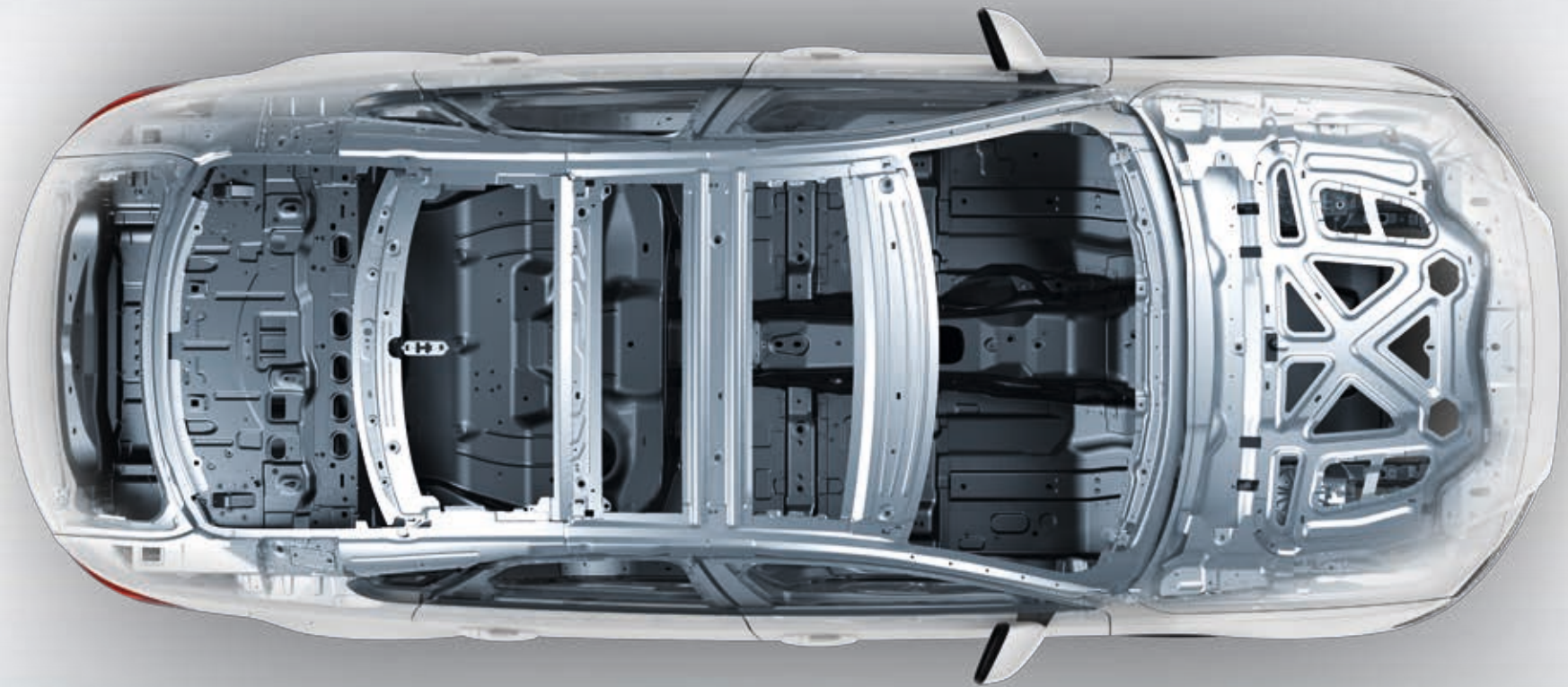

# LIGHTWEIGHT ALUMINIUM ARCHITECTURE

 **STRONG** | **RIGID** | **75% ALUMINIUM**

Jaguar has been at the forefront of aluminium car construction for more than a decade. The latest innovation is our high-strength Lightweight Aluminium Architecture, which is not only incredibly strong and reduces weight, it is also extremely stiff - underpinning XF's precise, agile handling. Aluminium has also been used to form the body sides, bonnet and front wings. These panels are bonded together with a super-strong adhesive, then punched with zinc-coated, boron steel rivets that compress the adhesive to form an airtight bond and a phenomenally strong, rigid structure. This cutting-edge process, coupled with the Lightweight Aluminium Architecture, makes XF among the lightest cars in its class. This weight saving facilitates fuel efficiency up to 4.0 l/100km (70.6mpg)\* and reduces CO<sub>2</sub> emissions to as low as 104g/km\*.

\*Engine performance and efficiency figures representative of XF Saloon only.  
For detailed XF Saloon and Sportbrake technical specifications, see pages 92 to 95.



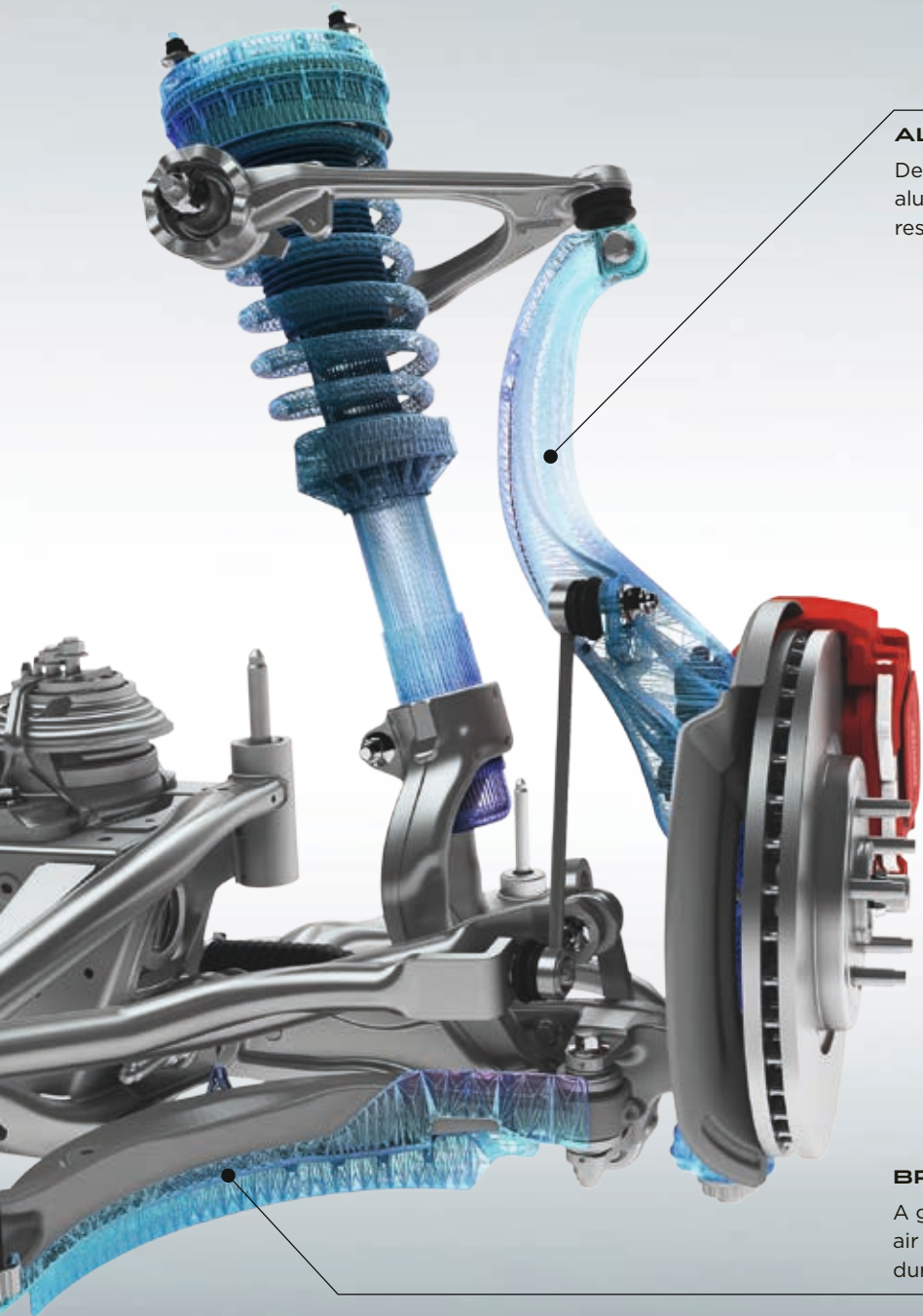

#### ALUMINIUM FRONT KNUCKLE

Designed to optimise stiffness and strength, the lightweight aluminium front knuckle helps improve XF's agility, responsiveness and refinement for sports car-like control.

## CHASSIS AND SUSPENSION



UNIQUE SUSPENSION  
TECHNOLOGY

COMFORTABLE  
AND DYNAMIC

XF responds with agility and performs with dynamism while always maintaining ride comfort – it's a unique balance that makes it a Jaguar. The ideal foundation for these driving dynamics is XF's light, yet exceptionally strong and stiff, Lightweight Aluminium Architecture with its near 50:50 weight distribution.

The sophisticated front and rear suspension systems complete a chassis that achieves a superb combination of sportiness and refinement. Advanced damper technologies – both passive or adaptive – improve ride quality still further and extend XF's breadth of dynamic capability. The suspension's control, agility and feedback give XF the spirit of a sports car.

#### BRAKE SCOOP

A glass-filled polypropylene brake scoop channels air onto the brakes for enhanced brake performance during enthusiastic driving.

### **INTEGRAL LINK REAR SUSPENSION**

Integral Link suspension allows XF to realise a perfect combination of a refined, luxurious ride and sharp, responsive handling. The system, the benchmark for this class of car, separates and independently manages the lateral, longitudinal and vertical forces acting on the suspension for enhanced control and comfort. Many components are forged or hollow-cast in aluminium – the optimum production techniques for strong, lightweight suspension.

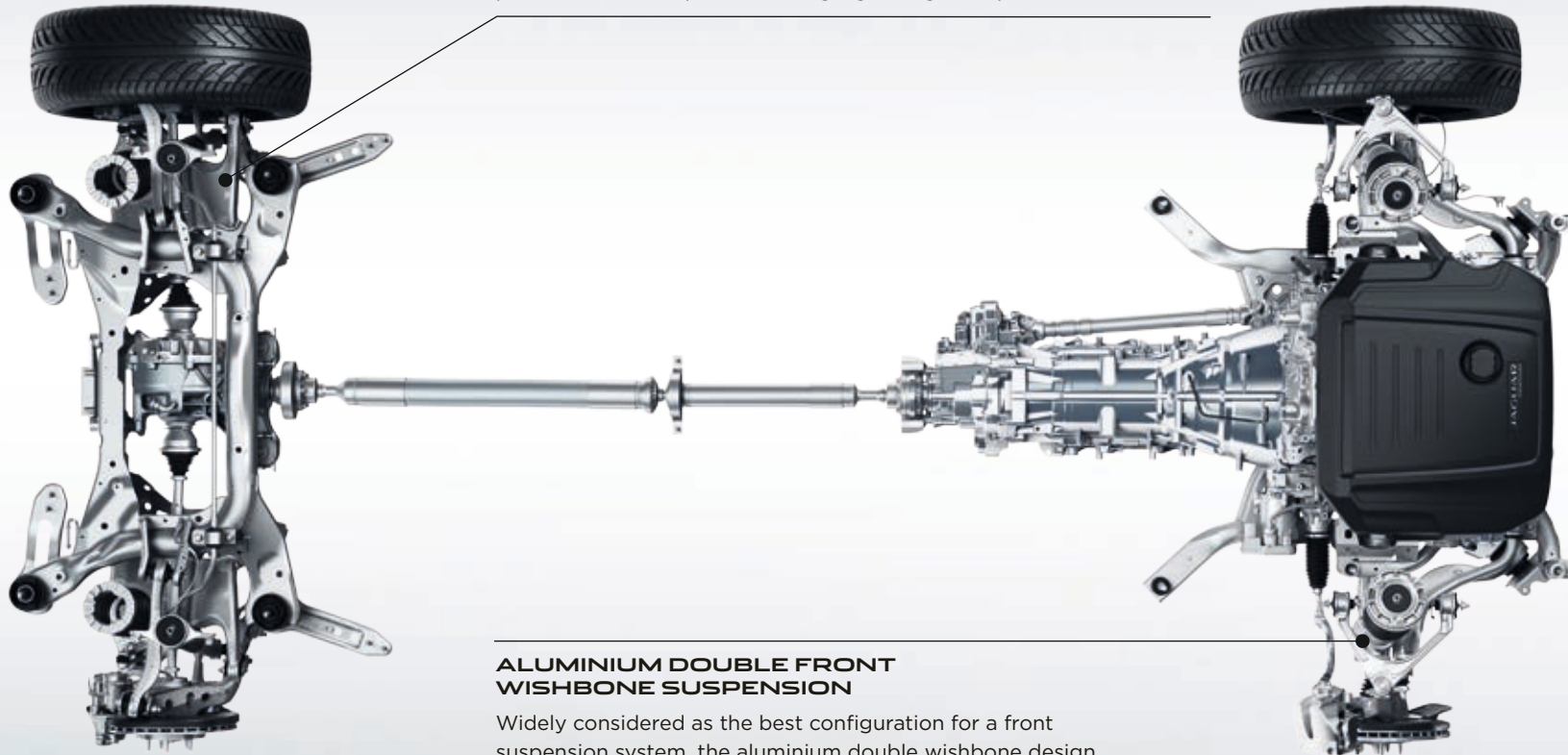

### **ALUMINIUM DOUBLE FRONT WISHBONE SUSPENSION**

Widely considered as the best configuration for a front suspension system, the aluminium double wishbone design is modelled closely on F-TYPE's for precise handling and steering response.



## DRIVING TECHNOLOGY

# ADVANCED DRIVING DYNAMICS

### > MAXIMISING AGILITY

Dynamic Mode revises the car's software to further enhance XF's sporting character. It sharpens the throttle response, increases steering weighting and performs gearshifts more quickly\* and at higher engine speeds. It also brings visual drama to the driver as the instrument cluster takes on a red glow. Dynamic Mode enhances your connection with XF's inherent Jaguar performance.

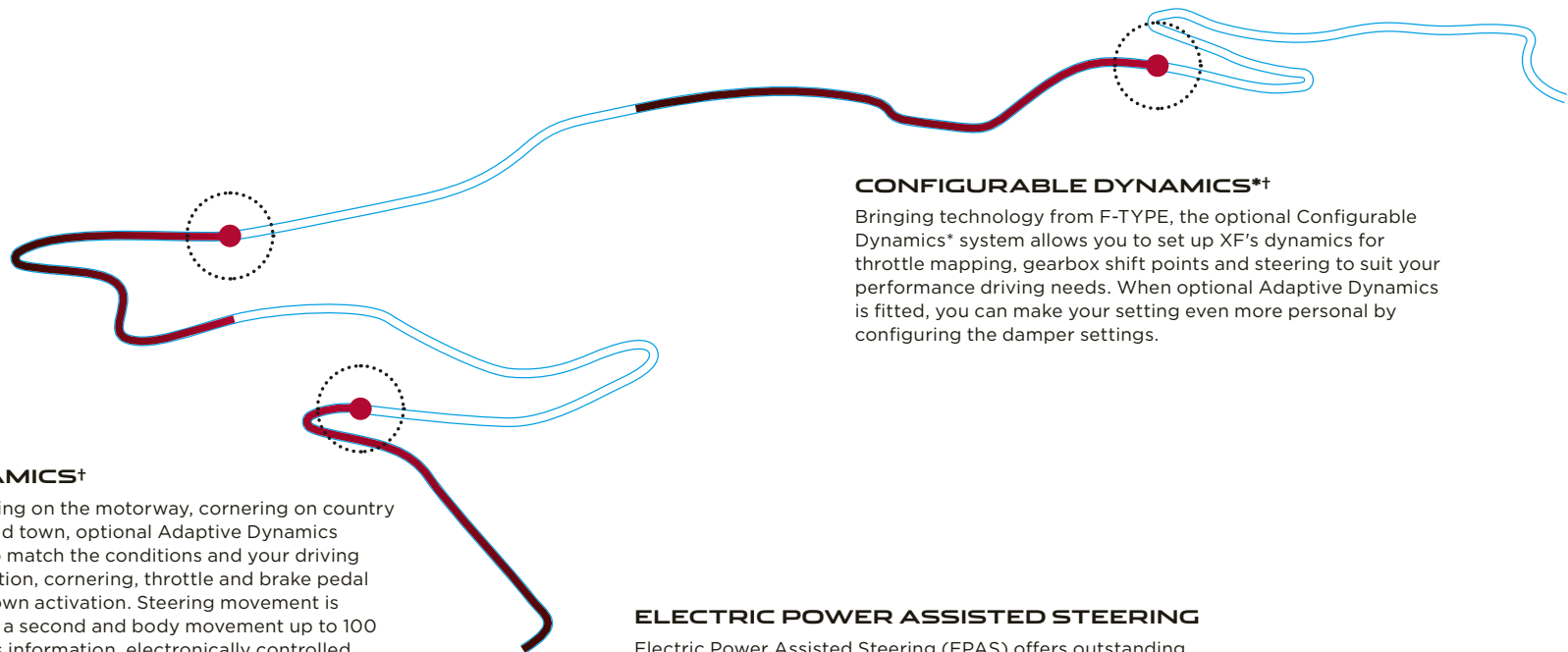

#### ADAPTIVE DYNAMICS†

Whether you're accelerating on the motorway, cornering on country roads or navigating around town, optional Adaptive Dynamics modifies XF's response to match the conditions and your driving style. It analyses acceleration, cornering, throttle and brake pedal activity, as well as kick-down activation. Steering movement is analysed up to 500 times a second and body movement up to 100 times a second. Using this information, electronically controlled adaptive dampers then constantly adjust to optimise the suspension settings and maintain XF's poise and comfort.

#### CONFIGURABLE DYNAMICS\*†

Bringing technology from F-TYPE, the optional Configurable Dynamics\* system allows you to set up XF's dynamics for throttle mapping, gearbox shift points and steering to suit your performance driving needs. When optional Adaptive Dynamics is fitted, you can make your setting even more personal by configuring the damper settings.

#### ELECTRIC POWER ASSISTED STEERING

Electric Power Assisted Steering (EPAS) offers outstanding feedback, control and it is active on demand - saving power for where you really need it, as well as saving fuel. EPAS' sophisticated computer management varies steering assistance as appropriate - increasing assistance for low speed manoeuvring and improving feel at higher speeds. It also enables advanced safety features such as Lane Keep Assist and Park Assist.

\*Automatic transmission only.

†Standard on XF S, not available on 2.0 litre 4 cylinder 163PS Diesel engine.

Standard and optional features may differ depending on market availability. Please consult your local Jaguar Retailer for details.







## ADDED DRIVER CONFIDENCE



ALL SURFACE PROGRESS CONTROL\*

ADAPTIVE SURFACE RESPONSE

Unique in this class of car, Jaguar's All Surface Progress Control (ASPC) technology is a low speed cruise control that helps XF to cope with low traction situations. ASPC allows the driver to concentrate on steering the vehicle. Once activated, you use the cruise control buttons to set a 'target' speed of between 3.6km/h and 30km/h. The system then works to achieve and maintain that speed while exerting optimum traction control.

ASPC is standard on all engines fitted with automatic transmissions and gives XF drivers added confidence over slippery, loose or icy surfaces, undulating terrain and even while descending a difficult incline. It helps make XF easy to drive in challenging conditions. ASPC also has a pull-away function allowing XF to progress from rest on low grip surfaces and ascending gradients, as well as a hill descent function that controls vehicle speed on steeper inclines.

On All Wheel Drive vehicles fitted with Adaptive Dynamics\*\*, optional Adaptive Surface Response (AdSR) recognises differences between surfaces to exploit the maximum available grip. Drawing on Jaguar Land Rover's unrivalled expertise with All Wheel Drive systems, AdSR constantly monitors the car's environment and adjusts the appropriate engine and brake settings. Once selected, AdSR works at all speeds to support you in adverse weather and across challenging surfaces.

\*Automatic transmission only.

\*\*Standard on XF S, not available on 2.0 litre 4 cylinder 163PS Diesel engine.

With any given set of tyres, ASPC can accomplish comparable levels of traction to that achievable by an expert driver. Fitting All-season or Winter tyres to XF can improve capability on slippery surfaces.

GRAVEL



WET GRASS



SNOW/ICE



WET ROAD





HBS 991

XF

# ADVANCED DRIVETRAIN TECHNOLOGY



ALL WHEEL DRIVE

INTELLIGENT DRIVELINE DYNAMICS

XF's All Wheel Drive (AWD) system combines the agility and character of Rear Wheel Drive (RWD) with the increased security and traction provided by AWD. In normal driving, XF is predominantly RWD to deliver handling purity, feel and balance. But when roads become more challenging, or when you accelerate more keenly on low-grip surfaces, the system subtly channels power forwards enabling XF to maintain optimum traction for comfortable progress in all conditions.

XF's AWD uses a transfer case at the back of the 8-speed Automatic Transmission to manage the appropriate distribution of torque to the front and rear wheels. Engineered to ensure that XF retains the dynamic behaviour of a Jaguar, the transfer case contains an electro-mechanically activated multi-plate clutch with an actuator to build hydraulic pressure. This pressure is quickly and accurately controlled to generate the required force in the clutch to transfer the optimal amount of torque to the front wheels.

Unlike other systems that react to wheel slip, Jaguar's Intelligent Driveline Dynamics (IDD) software is predictive and uses sensors measuring throttle and steering inputs to anticipate wheel slip. IDD seamlessly co-ordinates these inputs and compares them with responses from the engine, transmission and traction control systems to calculate the traction available and distribute torque accordingly even before grip is lost. From a standstill XF can transition from RWD to AWD in as little as 165 milliseconds or just 100 milliseconds when the car is moving. The result is a drive which blends the character of RWD with the capability of AWD, providing outstanding levels of performance and control whatever the road throws at you.

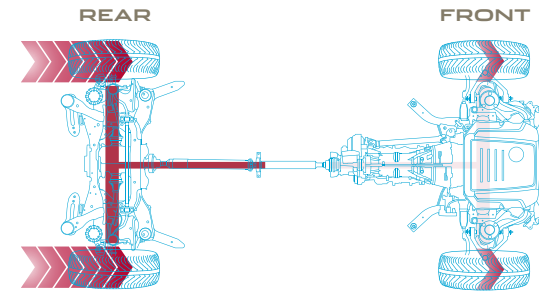

## DRY ROAD CONDITIONS

In normal conditions, torque is distributed to the rear wheels, delivering acclaimed Jaguar agility and handling.

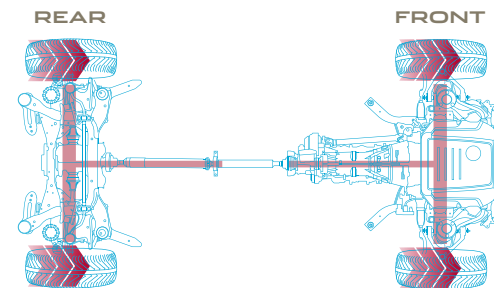

## LOW TRACTION CONDITIONS

On slippery surfaces, such as grass and snow, torque can be balanced between the front and rear wheels to maximise traction. In extreme conditions where only the front wheels have traction, up to 100 percent of engine torque can be distributed to the front wheels for optimum grip.

VEHICLE SHOWN: XF SALOON S IN YULONG WHITE WITH OPTIONAL FEATURES FITTED (MARKET DEPENDENT)





# TORQUE VECTORING

## ➤ MAXIMISED CORNERING CAPABILITY

XF's Torque Vectoring by Braking maximises capability through even the tightest corners. Torque Vectoring technology provides controlled independent braking on the individual inside front and rear wheels to add to the turning forces acting on the car. In most conditions more braking pressure is applied to the rear inside wheel as this supports the most increased cornering capability, while the front inside wheel is braked for greater effectiveness and refinement. The result is reduced understeer for sharper turning and more consistent road holding. Torque Vectoring delivers increased sports car-like agility and added driver confidence.

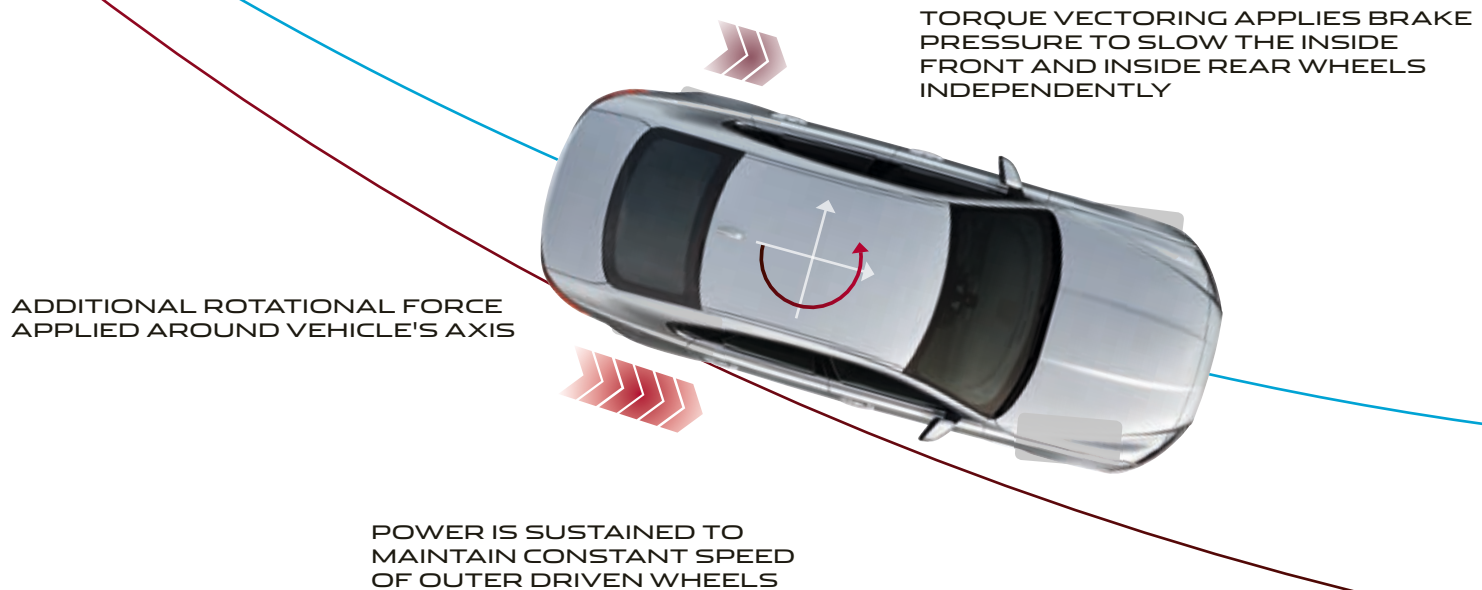

Graphical representation only.

VEHICLE SHOWN PREVIOUS PAGE: XF SALOON S IN YULONG WHITE WITH OPTIONAL FEATURES FITTED (MARKET DEPENDENT)





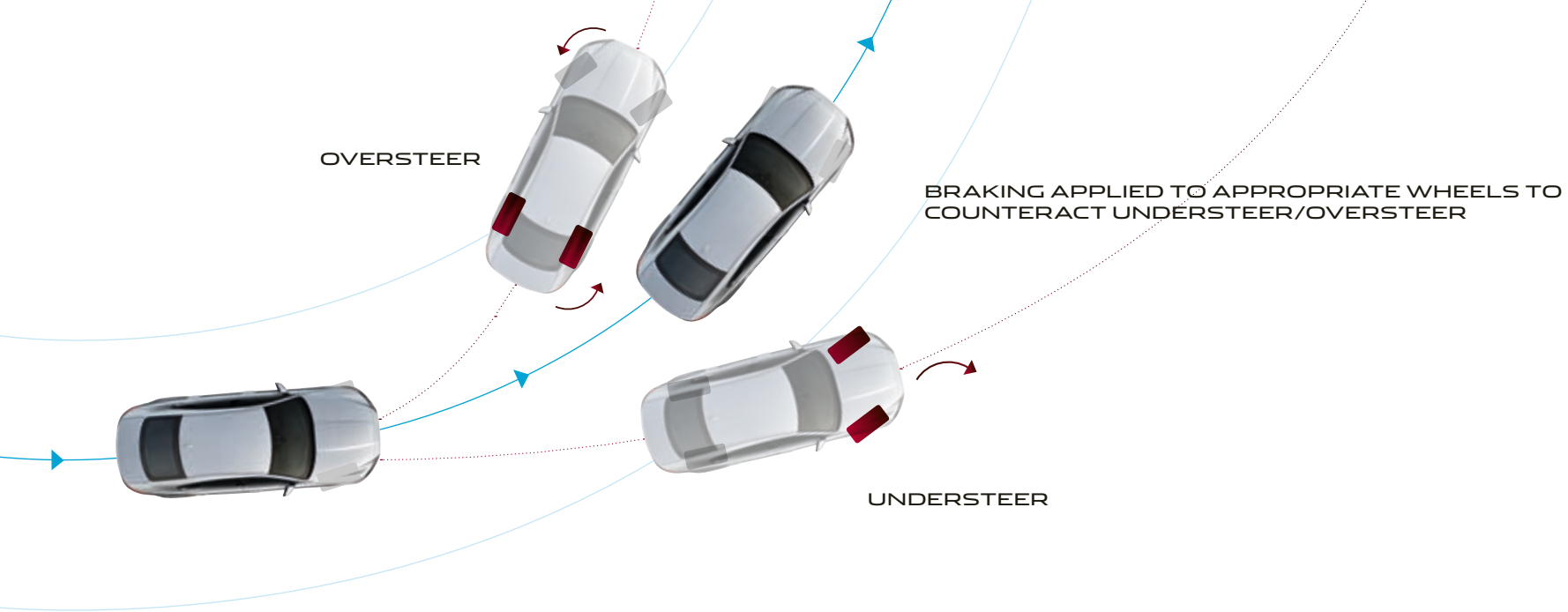

## STABILITY AND CONTROL



**DYNAMIC STABILITY CONTROL**

**ENGINE DRAG TORQUE CONTROL**

**TRAILER STABILITY ASSIST**

Jaguar's Stability Systems keep XF safely balanced whether you're driving enthusiastically or simply want the assurance of a car that will remain stable in challenging conditions.

**Dynamic Stability Control (DSC)** monitors XF's dynamic behaviour, intervening to maximise vehicle stability and optimising available grip. DSC reduces engine torque and applies braking to the appropriate wheels to correct the car's direction of travel by counteracting understeer or oversteer. XF's DSC system has enhanced understeer control to reduce speed and regain control more effectively.

**Engine Drag Torque Control (EDC)** mitigates the chance of wheel lock-up caused by strong engine braking in slippery conditions. It acts by briefly increasing torque to the driven wheels as appropriate.

**Trailer Stability Assist (TSA)** gives you greater stability when towing. Should TSA detect a dangerous trailer sway situation is developing, it can help you regain control by gradually reducing XF's speed through lowering engine power and applying the brakes individually on each side of the vehicle to control the sway.

Graphical representation only.

VEHICLE SHOWN PREVIOUS PAGE: XF SALOON S IN YULONG WHITE WITH OPTIONAL FEATURES FITTED (MARKET DEPENDENT)





95  
90 km/h 100

Darkness  
Oliver Daldry  
Darkness  
6/12

140 160 180 200 220 240 260 280 300  
km/h  
90  
95 km/h

rpm x 1000  
3 4 5 6 7  
5

17:06

15°C

SET +



# HEAD-UP DISPLAY

## > HEAD-UP DISPLAY WITH LASER TECHNOLOGY

The Head-up Display (HUD)\* with laser technology projects key information onto the windscreen. Remaining clear even in direct sunlight, the crisp, bright image can display vehicle speed, navigation, cruise control notifications and Traffic Sign Recognition data, where available. This technology helps you minimise time spent looking down at the instrument cluster and can help you maintain continuous awareness of the car's speed.

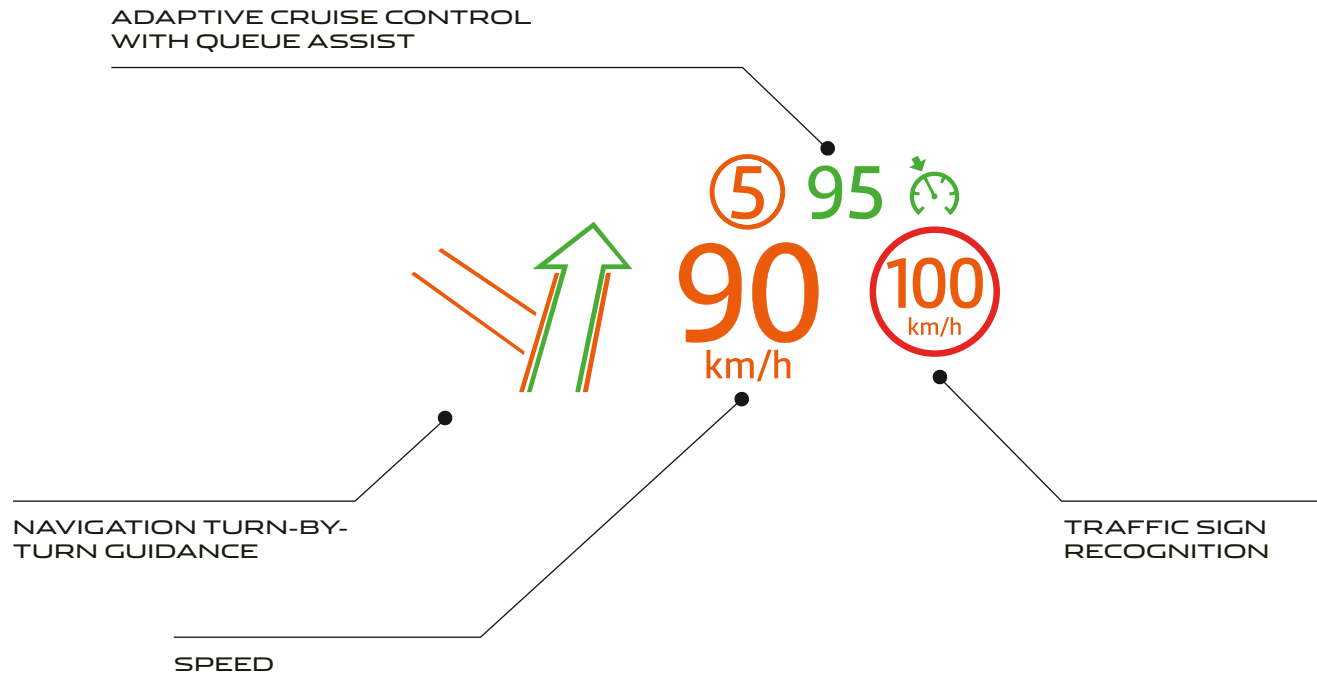

\*Requires infrared reflective windscreen to be fitted.

Standard and optional features may differ depending on market availability. Please consult your local Jaguar Retailer for details.



## INCONTROL TECHNOLOGIES INFOTAINMENT AND CONNECTIVITY

 TOUCH | TOUCH PRO

InControl\* is our suite of advanced technologies that links both you and your XF to the wider world. Choose from two InControl infotainment systems: Touch, available as standard, or upgrade to Touch Pro. These can be further enhanced by adding their respective connectivity packages, Connect and Connect Pro\*\*.

\*As we roll out InControl, specific features described may be optional, and market or powertrain dependent. Please consult your country-specific Jaguar website or local Jaguar Retailer for availability and full terms in your country. Certain features require an appropriate SIM with a suitable data contract which will require further subscription after the initial term advised by your Retailer. Mobile connectivity cannot be guaranteed in all locations.

\*\*In selected markets where Navigation Pro is fitted you must select all the features of Connect Pro. Please consult your local Jaguar Retailer for further details.

†Only available with InControl Apps or Connect Pro (see optional connectivity packages for Touch Pro).

Third Party programmes or applications may require an end user license from the supplier.



**TOUCH**



**STANDARD ON EVERY XF**

8" Touchscreen  
 Instrument Cluster with 5" Central TFT Display  
 Jaguar Sound System (80W)  
 AM/FM Radio  
 USB, Bluetooth® and AUX connections



**Protect** consists of  
 SOS Emergency Call, Jaguar Optimised Assistance and  
 Remote Essentials smartphone app



**OPTIONAL**

**Connect** consists of InControl Apps, Remote Premium  
 smartphone app and Wi-Fi Hotspot



**Secure Tracker** provides Stolen Vehicle Monitoring and  
 notifications via your smartphone and the secure call centre

**ADDITIONAL OPTIONS**

Meridian™ Sound System (380W)  
 Navigation  
 DAB Radio  
 InControl Apps



**TOUCH PRO**



**AVAILABLE AS AN UPGRADE**

10.2" Touchscreen with multi-touch gestures and  
 customisable homescreen  
 12.3" Instrument Panel Display with virtual dials and full  
 screen 3D Map View  
 Navigation Pro  
 Meridian™ Sound System (380W)  
 AM/FM Radio, Bluetooth® and 2 x USB connections  
 10GB of usable memory  
 CD/DVD Drive



**Protect** consists of  
 SOS Emergency Call, Jaguar Optimised Assistance and  
 Remote Essentials smartphone app



**OPTIONAL**

**Connect Pro\*\*** consists of InControl Apps, Remote Premium  
 smartphone app, Wi-Fi Hotspot and Pro Services including  
 Real Time Traffic information



**Secure Tracker** provides Stolen Vehicle Monitoring and  
 notifications via your smartphone and the secure call centre

**ADDITIONAL OPTIONS**

Meridian™ Surround Sound System (825W)  
 Digital TV, HDMI†, MHL†  
 DAB Radio  
 Dual View  
 InControl Apps





8" TOUCHSCREEN SHOWN AT ACTUAL SIZE

<b>Audio</b>	Jaguar Sound System (80W) Meridian™ Sound System (380W)
<b>Navigation Guidance</b>	Navigation
<b>Display</b>	8" Touchscreen
<b>Multimedia</b>	AM/FM and DAB Radio, 1 x USB, Bluetooth® and 1 x AUX connection
<b>Standard InControl Package</b>	Protect consists of SOS Emergency Call, Jaguar Optimised Assistance and Remote Essentials smartphone app
<b>Optional Connectivity Package</b>	Connect consists of InControl Apps, Remote Premium smartphone app and Wi-Fi Hotspot

# TOUCH



## ADVANCED INFOTAINMENT AS STANDARD

The Touch multimedia system is XF's hub for connectivity, control and entertainment. The key features are:

**8" Touchscreen** at the heart of the centre console. Clear and responsive graphical interface for quick control.

**Easy to use Touchscreen** responds directly to touch and swipe gestures.

**Navigation guidance** makes planning journeys and following routes easy, thanks to turn-by-turn voice guidance and junction view. 'Dead-reckoning' functionality can accurately position the vehicle even when GPS signals can no longer be received - perfect for city centres or driving through tunnels.

**Bluetooth phone connectivity** allows you to link and control your smartphone via Touch either for phone calls or music playback: simple, easy and wire-free.

**Access a world of music** thanks to AM/FM, DAB Radio, as well as USB and AUX connections.

**Integrated text-to-voice** technology reduces distraction by reading out incoming text messages. You can easily respond with short, prepared messages.

**Precise climate control** is available via the Touchscreen. Adjust temperature levels, direction and intensity of airflow and operate heated or cooled seats (if fitted).

# CONNECT



## OPTIONAL CONNECTIVITY PACKAGE

Connect is a bundle of technologies and applications that takes your XF's connectivity to the next level.

**InControl Apps** features a range of bespoke Jaguar approved apps that can be connected to the car from your smartphone. It ensures the safe and convenient use of these apps that have been optimised specifically to enhance aspects of your in-car experience.

**Wi-Fi Hotspot** gives you the option to create a 3G hotspot using the car's antenna when you fit a SIM card. This strengthens your link to the outside world, for a more stable connection than an individual device could maintain. Connect up to eight devices to read emails, browse the web and download content.

**Remote Premium** is a multi-function app that allows you to monitor as well as interact with your XF from your smartphone. Remote start the engine to pre-condition the climate, lock and unlock the car, locate your XF on a map or by using the beep and flash function, and track your journeys - all via the app.



Explore InControl at [jaguar.com/incontrol](http://jaguar.com/incontrol)

As we roll out InControl, specific features described may be optional, and market or powertrain dependent. Please consult your country-specific Jaguar website or local Jaguar Retailer for availability and full terms in your country. Certain features require an appropriate SIM with a suitable data contract which will require further subscription after the initial term advised by your Retailer. Mobile connectivity cannot be guaranteed in all locations.





10.2" TOUCHSCREEN SHOWN AT ACTUAL SIZE

<b>Audio</b>	Meridian™ Sound System (380W) Meridian™ Surround Sound System (825W)
<b>Navigation Guidance</b>	Navigation Pro
<b>Display</b>	10.2" Touchscreen
<b>Multimedia</b>	AM/FM and DAB Radio, Dual View, Bluetooth®, HDMI, MHL and 2 x USB connections. Digital TV, 10GB of usable memory and CD/DVD Drive
<b>Standard InControl Package</b>	Protect consists of SOS Emergency Call, Jaguar Optimised Assistance and Remote Essentials
<b>Optional Connectivity Package</b>	Connect Pro consists of InControl Apps, Remote Premium, Wi-Fi Hotspot and Pro Services (including Route Planner Companion App, share your destination and ETA, Commute Mode, Arrival Mode, Real Time Traffic information and fuel and parking services)



12.3" Full Digital Instrument Panel with virtual dials

# TOUCH PRO

## UPGRADE TO NEXT GENERATION INFOTAINMENT

Touch Pro's next-generation hardware and software advances XF's connectivity and entertainment to the very highest level. Touch Pro's features replace or enhance those found in Touch. The key aspects of Touch Pro are:

**Larger, highly-responsive, 10.2" Touchscreen** at the heart of the centre console with customisable homescreen and lightning fast response times. Its interactive side panel makes multi-tasking easy.

**Pinpoint touch control** allows you to manipulate and interact with information swiftly and seamlessly. The Touchscreen responds in the same manner as a smartphone or tablet computer, providing multi-touch gestures such as pinch to zoom and swipe.

**12.3" Instrument Panel Display with Virtual Dials** and full screen 3D Map View makes driving even more of a pleasure. It is housed in the instrument display directly in front of the driver. Select full screen 3D Map View or choose one of four graphical themes to suit your personal preference.

**Enhanced Navigation** with faster response times. One of the many innovative features of Touch Pro's Navigation is that it allows you to set a destination and the system alerts you if you have insufficient fuel for the journey. It then displays filling stations on the part of the route where you may be low on fuel. The system automatically displays parking options.

**Personal media storage** of 10GB of usable memory for your music and movies. 'Plug and play' using the two USB ports allowing for fast transfer speeds.

**Dual View** allows the front passenger and driver to enjoy different media on the same 10.2" Touchscreen. For example, the front passenger can watch a film (listening to the audio with wireless headphones) while the driver views navigation.



Explore InControl at [jaguar.com/incontrol](http://jaguar.com/incontrol)

As we roll out InControl, specific features described may be optional, and market or powertrain dependent. Please consult your country-specific Jaguar website or local Jaguar Retailer for availability and full terms in your country. Certain features require an appropriate SIM with a suitable data contract which will require further subscription after the initial term advised by your Retailer. Mobile connectivity cannot be guaranteed in all locations.

# CONNECT PRO

## OPTIONAL ENHANCED CONNECTIVITY PACKAGE

Connect Pro's services, technologies and applications give you the very best in connectivity and convenience. It offers all the benefits of Connect (see pg. 47) plus many more features, including:

**Route Planner Companion App** offers true door-to-door navigation. Pre-plan your destination and route via your Apple or Android smartphone. The app will guide you to your car, where you will find your selected route available on the car's Touchscreen. When you've completed your road journey, the app can guide you by foot or public transport (where supported) to your destination.

**Real Time Traffic** uses millions of live traffic data feeds to give a highly accurate picture of traffic on the way to your destination, helping you choose the best route. As you progress, the system continues to monitor live traffic conditions, and can automatically reroute you to help avoid congestion.

**Share your estimated time of arrival** so your selected contact(s) will know exactly when you will arrive, as calculated by the navigation guidance system. If you're running late, the system can then send automatic updates via text or email, without any further action from you.

**Commute Mode** allows the system to learn your commutes and automatically advises you of the expected journey time based on live and historical traffic movements. The system learns the routes you take for a given destination and then advises which of those is the quickest.

**Arrival Mode** displays interactive 360° street level imagery of your destination for seamless finishes to journeys. It automatically displays again upon your arrival. You then simply tap the Touchscreen to select a nearby car park, which appears as an updated destination.



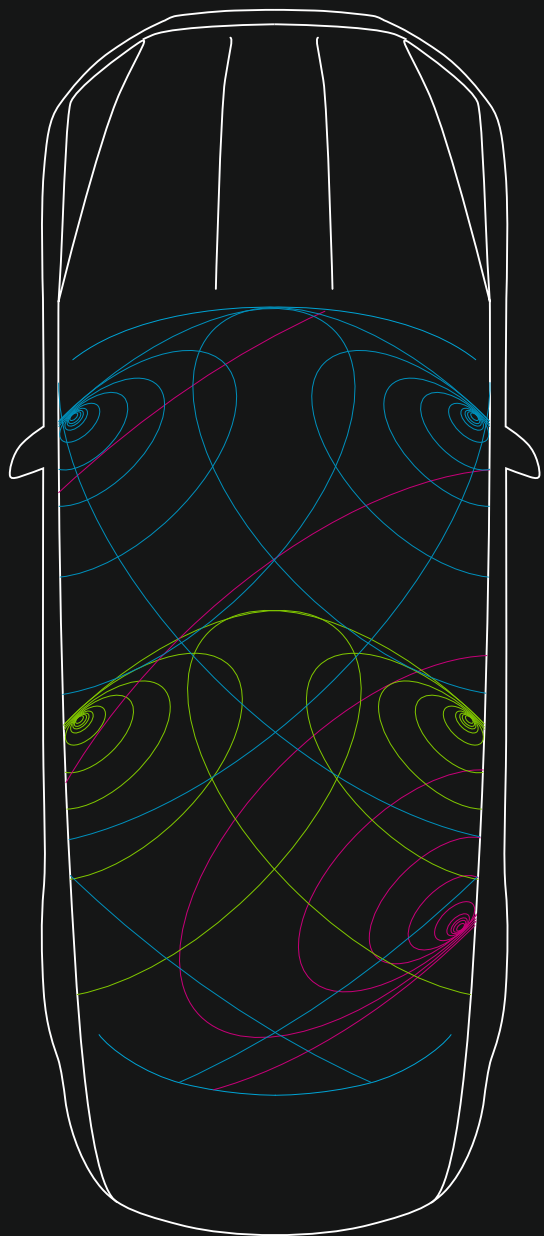

## AUDIO

 JAGUAR  
SOUND SYSTEM

MERIDIAN™  
SOUND SYSTEMS

XF's superb sound systems bring your music to life. The Jaguar Sound System provides acoustic range through 8 speakers. Offering an enhanced listening experience are the optional Meridian™ Sound Systems. Designed in conjunction with the British audio experts Meridian™, these systems use innovative audio technology and precise speaker placement to give perfectly optimised sound quality.

Choose from a range of sound systems, including the new 380W Sound System with 11 speakers or the 825W Surround Sound System with 17 speakers. All ensure that, wherever you or your passengers sit in your XF, everyone will enjoy a rich, enveloping audio experience.



-  Fresh air subwoofer
-  Front door waves tweeter midrange bass
-  Rear door waves tweeter midrange

Diagram representative of Meridian™ 380W Sound System.



MERIDIAN

SOUND SYSTEMS AVAILABLE IN CONJUNCTION WITH TOUCH

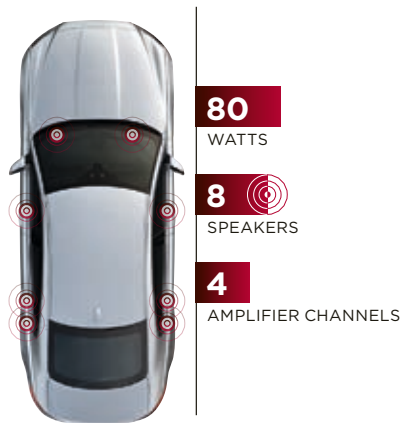

**JAGUAR SOUND SYSTEM**

Speed Dependent Volume\*  
80 watts  
8 speakers  
4 amplifier channels

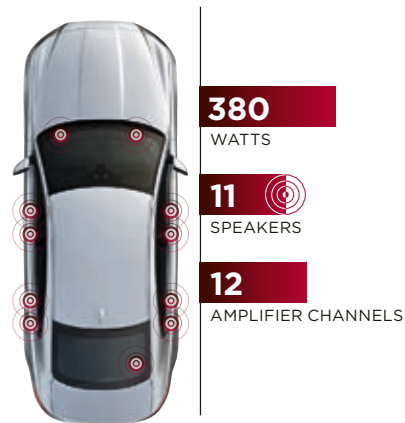

**MERIDIAN™ SOUND SYSTEM**

DSP amplifier  
Speed Dependent Volume\*  
380 watts  
11 speakers  
12 amplifier channels

SOUND SYSTEMS AVAILABLE IN CONJUNCTION WITH TOUCH PRO

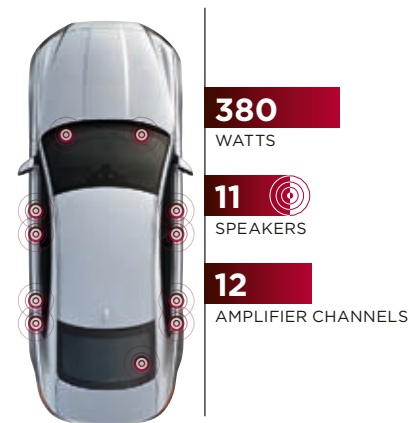

**MERIDIAN™ SOUND SYSTEM**

DSP amplifier  
Audyssey MultEQ Audio Equalisation  
Dynamic Volume Control\*\*  
380 watts  
11 speakers  
12 amplifier channels

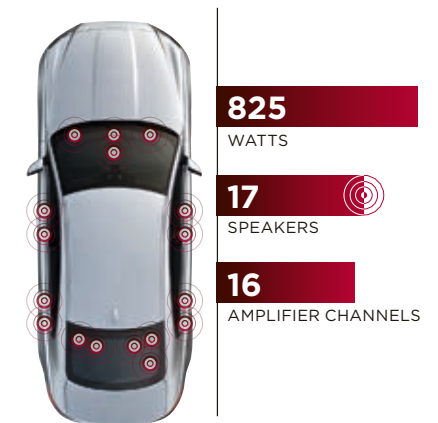

**MERIDIAN™ SURROUND SOUND SYSTEM**

DSP amplifier  
Audyssey MultEQ Audio Equalisation  
Dynamic Volume Control\*\*  
825 watts  
17 speakers  
16 amplifier channels

\*Automatically adjusts as vehicle speed changes.

\*\*Automatically adjusts as vehicle speed changes and/or ambient noise levels change.

Graphical representations only. Indicative of speaker positions in both XF Saloon and XF Sportbrake. Standard and optional features may differ depending on market availability. Please consult your local Jaguar Retailer for details.

VEHICLE SHOWN: XF SALOON PRESTIGE IN INDUS SILVER WITH OPTIONAL FEATURES FITTED (MARKET DEPENDENT)



# SAFETY

## ADVANCED DRIVER ASSISTANCE



### 1 AUTONOMOUS EMERGENCY BRAKING

Should a potential collision be detected, XF gives an audible forward collision warning. Visual warnings follow. If the driver takes no action the system applies the brakes to help reduce the severity of the possible impact.

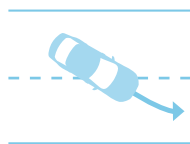

### 2 LANE DEPARTURE WARNING

Lane Departure Warning notifies the driver with a visual alert and a gentle vibration of the steering wheel should the car detect an unintentional drift from its lane, helping to keep everyone on board safe.

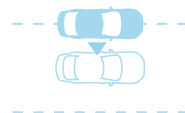

### 3 LANE KEEP ASSIST AND DRIVER CONDITION MONITOR

Building on Lane Departure Warning, Lane Keep Assist (LKA) senses unintentional lane drift and helps steer XF back into its lane. Driver Condition Monitor (DCM) detects lapses in concentration due to tiredness by monitoring driver inputs and suggests taking a break via an audible alert and a visual notification in the instrument cluster.

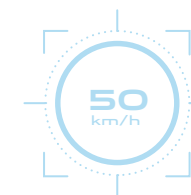

### 4 TRAFFIC SIGN RECOGNITION WITH ADAPTIVE SPEED LIMITER

Traffic Sign Recognition (TSR) technology detects speed limits, including variable limits, and no overtaking signs via the forward-facing camera, then displays them to the driver. The Adaptive Speed Limiter uses TSR's information, supported by map data from the optional navigation system, to help keep XF within the appropriate speed limit.



### 5 PARK ASSIST

Park Assist makes parking in tight spaces easier than ever. XF can accurately steer itself during both parallel and bay parking manoeuvres – the driver only has to control the brakes and accelerator. An exit-assist function can help guide XF while leaving a parallel space.



### 6 BLIND SPOT ASSIST AND REVERSE TRAFFIC DETECTION

If your car detects another vehicle in or quickly approaching your blind spot, the Blind Spot Monitor system alerts you via a small warning light in the corresponding exterior mirror. As an enhancement to this, Blind Spot Assist will apply steering torque to guide you away from the vehicle in your blind spot if you begin to change lanes. Using the same radar system, Reverse Traffic Detection alerts you via the Touchscreen of moving vehicles during reversing – for example, when leaving a parking bay with restricted vision.

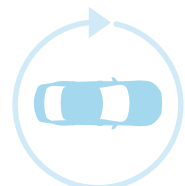

### 7 SURROUND CAMERA SYSTEM

Helping with various manoeuvres, from parking by a kerb to getting in and out of tight spaces and junctions, Surround Camera System gives you 360° exterior vision on the Touchscreen. To enhance this system further, new Forward Vehicle Guidance and Forward Traffic Detection are also included. Forming part of the Surround Camera System, Forward Vehicle Guidance provides the driver with an on-screen visualisation of the vehicle and parking distance. Forward Traffic Detection helps avoid potential collisions in situations where forward manoeuvres involve restricted views.



### 8 ADAPTIVE CRUISE CONTROL WITH QUEUE ASSIST

Adaptive Cruise Control\* uses radar technology to automatically adjust your speed to maintain a safe distance from the vehicle ahead. If that vehicle slows, your XF reduces its speed to maintain a safe distance. XF resumes its pre-set speed as soon as the road in front is clear. Should the car in front stop completely, the Queue Assist function brings XF to a smooth halt. Once the traffic moves off, touch the accelerator and XF will follow the car in front again.

\*Only available with automatic transmission.

Standard and optional features, may differ depending on market availability. Please consult your local Jaguar Retailer for details.

VEHICLE SHOWN: XF SALOON PRESTIGE IN INDUS SILVER WITH OPTIONAL FEATURES FITTED (MARKET DEPENDENT)

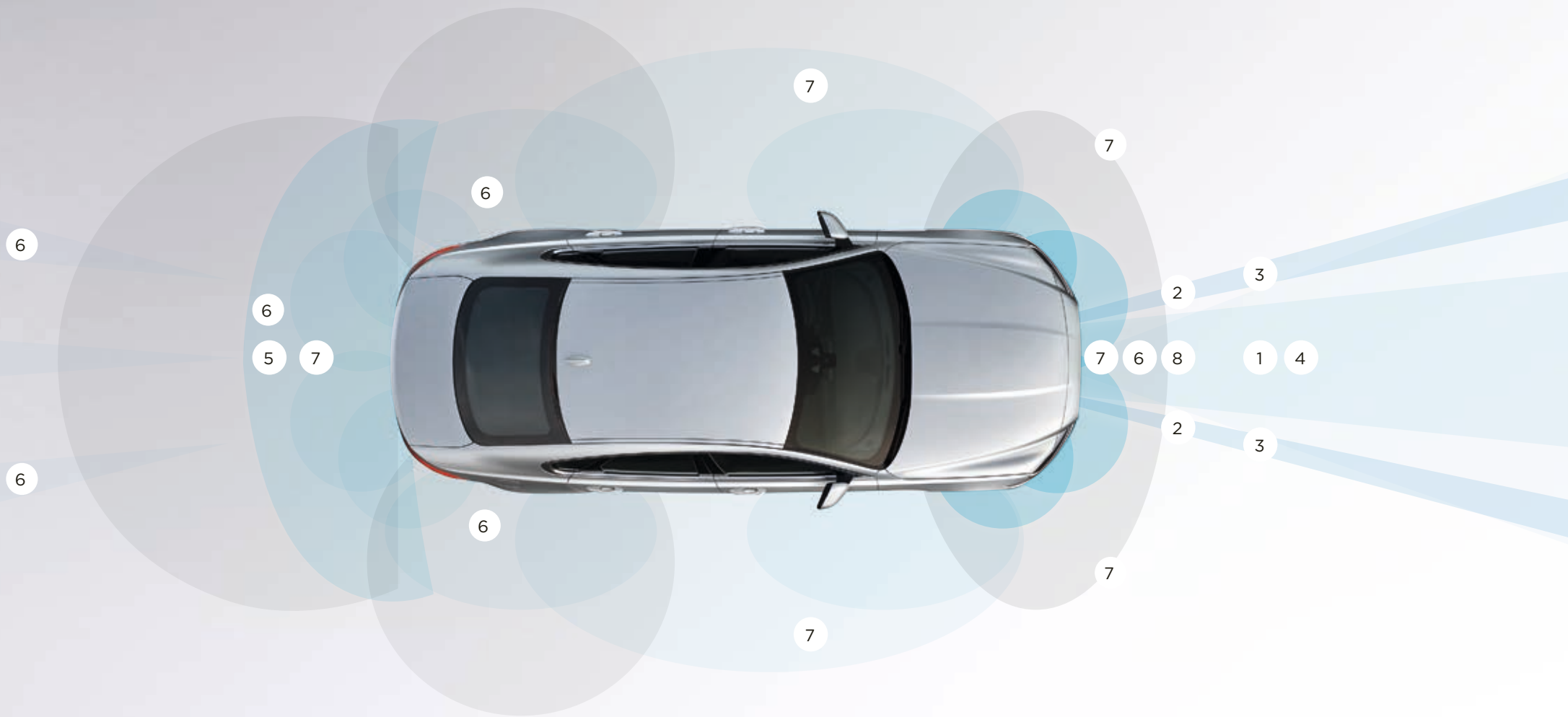

Graphical representation only.



# PERSONALISATION XF - YOUR CHOICE

 Configure your vehicle at [jaguar.com](http://jaguar.com)



## CHOOSE YOUR ENGINE

### Page 56

Select one of XF's powerful, efficient petrol or diesel engines to suit your driving style.

## CHOOSE YOUR MODEL

### Page 60

Compare the wealth of features on XF models.

## CHOOSE YOUR COLOUR

### Page 62

Express your individuality with one of XF's stunning exterior colours.



CHOOSE YOUR  
**WHEELS**

**Page 64**

Add the personal finishing touch to your new XF, and complement its stunning style, with a set of beautifully designed alloy wheels.



CHOOSE YOUR  
**INTERIOR**

**Page 66**

There's a wide selection of premium materials, leathers, veneers and finishes for every personal taste.



CHOOSE YOUR  
**JAGUAR GEAR**

**Page 84**

Really make it yours by adding style, practicality and versatility with official XF Gear Accessories from your local Jaguar Retailer.



# 1 CHOOSE YOUR ENGINE

 Configure your vehicle at [jaguar.com](http://jaguar.com)

## > DIESEL ENGINES

### 2.0 LITRE

4 CYLINDER TURBOCHARGED E-PERFORMANCE

#### XF SALOON

MAXIMUM POWER 163PS

MAXIMUM TORQUE 380Nm

ACCELERATION 0-100 km/h  
Manual RWD / Automatic RWD 8.7 seconds

TOP SPEED  
Manual RWD 229 km/h Automatic RWD 227 km/h

COMBINED FUEL CONSUMPTION  
Manual RWD 4.0 l/100km Automatic RWD 4.1 l/100km

COMBINED CO<sub>2</sub> Manual 104 g/km Automatic 109 g/km

PURE, PRESTIGE, PORTFOLIO, R-SPORT

#### XF SPORTBRAKE

MAXIMUM POWER 163PS

MAXIMUM TORQUE 380Nm

ACCELERATION 0-100 km/h  
Manual RWD 9.3 seconds  
Automatic RWD 9.4 seconds

TOP SPEED  
Manual RWD / Automatic RWD 219 km/h

COMBINED FUEL CONSUMPTION  
RWD 4.5 l/100km

COMBINED CO<sub>2</sub> Manual 118 g/km Automatic 119 g/km

PURE, PRESTIGE, PORTFOLIO, R-SPORT

### 2.0 LITRE

4 CYLINDER TURBOCHARGED

#### XF SALOON

MAXIMUM POWER 180PS

MAXIMUM TORQUE 430Nm

ACCELERATION 0-100 km/h  
Manual RWD 8.0 seconds  
Automatic RWD 8.1 seconds Automatic AWD 8.4 seconds

TOP SPEED Manual RWD 230 km/h /  
Automatic RWD 229 km/h Automatic AWD 222 km/h

COMBINED FUEL CONSUMPTION  
RWD 4.3 l/100km AWD 4.9 l/100km

COMBINED CO<sub>2</sub> RWD 114 g/km AWD 129 g/km

PURE, PRESTIGE, PORTFOLIO, R-SPORT

#### XF SPORTBRAKE

MAXIMUM POWER 180PS

MAXIMUM TORQUE 430Nm

ACCELERATION 0-100 km/h  
Automatic RWD 8.8 seconds  
Automatic AWD 8.9 seconds

TOP SPEED  
Automatic RWD 221 km/h Automatic AWD 219 km/h

COMBINED FUEL CONSUMPTION  
RWD 4.6 l/100km AWD 5.0 l/100km

COMBINED CO<sub>2</sub> RWD 120 g/km AWD 132 g/km

PURE, PRESTIGE, PORTFOLIO, R-SPORT



MANUAL  
0-100 KM/H



AUTOMATIC  
0-100 KM/H



MANUAL  
0-100 KM/H



AUTOMATIC  
0-100 KM/H



MANUAL RWD  
0-100 KM/H



AUTOMATIC RWD  
0-100 KM/H



AUTOMATIC AWD  
0-100 KM/H



AUTOMATIC RWD  
0-100 KM/H



AUTOMATIC AWD  
0-100 KM/H



MANUAL  
TOP SPEED KM/H



AUTOMATIC  
TOP SPEED KM/H



MANUAL  
TOP SPEED KM/H



AUTOMATIC  
TOP SPEED KM/H



MANUAL  
TOP SPEED KM/H



AUTOMATIC RWD  
TOP SPEED KM/H



AUTOMATIC AWD  
TOP SPEED KM/H



AUTOMATIC RWD  
TOP SPEED KM/H



AUTOMATIC AWD  
TOP SPEED KM/H

\*With 18" wheel. 5.9 l/100km if car fitted with 19/20" wheels. \*\*With 18" wheel. 154 g/km if car fitted with 19/20" wheels.

Please refer to Technical Specification pages for full fuel consumption figures.

The figures provided are as a result of official manufacturer's tests in accordance with EU legislation.

A vehicle's actual fuel consumption may differ from that achieved in such tests and these figures are for comparative purposes only.

Engine availability is market dependent. Please consult your local Jaguar Retailer for details.

## 2.0 LITRE

4 CYLINDER TWIN TURBOCHARGED

### XF SALOON

MAXIMUM POWER 240PS

MAXIMUM TORQUE 500Nm

ACCELERATION 0-100 km/h  
Automatic RWD/AWD 6.5 seconds

TOP SPEED  
Automatic RWD/AWD 246 km/h

COMBINED FUEL CONSUMPTION  
RWD 5.3 l/100km AWD 5.5 l/100km

COMBINED CO<sub>2</sub> RWD 139 g/km AWD 144 g/km

PURE, PRESTIGE, PORTFOLIO, R-SPORT

### XF SPORTBRAKE

MAXIMUM POWER 240PS

MAXIMUM TORQUE 500Nm

ACCELERATION 0-100 km/h  
Automatic AWD 6.7 seconds

TOP SPEED  
Automatic AWD 241 km/h

COMBINED FUEL CONSUMPTION  
AWD 5.8 l/100km

COMBINED CO<sub>2</sub> AWD 153 g/km

PRESTIGE, PORTFOLIO, R-SPORT

## 3.0 LITRE V6

6 CYLINDER TWIN TURBOCHARGED

### XF SALOON

MAXIMUM POWER 300PS

MAXIMUM TORQUE 700Nm

ACCELERATION 0-100 km/h  
Automatic RWD 6.2 seconds

TOP SPEED  
Automatic RWD 250 km/h

COMBINED FUEL CONSUMPTION  
RWD 5.5 l/100km

COMBINED CO<sub>2</sub> RWD 144 g/km

PRESTIGE, PORTFOLIO, R-SPORT

### XF SPORTBRAKE

MAXIMUM POWER 300PS

MAXIMUM TORQUE 700Nm

ACCELERATION 0-100 km/h  
Automatic RWD 6.6 seconds

TOP SPEED  
Automatic RWD 250 km/h

COMBINED FUEL CONSUMPTION  
RWD 5.7 l/100km\*

COMBINED CO<sub>2</sub> RWD 149 g/km\*\*

PORTFOLIO, S



AUTOMATIC RWD  
0-100 KM/H



AUTOMATIC AWD  
0-100 KM/H



AUTOMATIC AWD  
0-100 KM/H



AUTOMATIC RWD  
0-100 KM/H



AUTOMATIC RWD  
0-100 KM/H



AUTOMATIC RWD  
TOP SPEED KM/H



AUTOMATIC AWD  
TOP SPEED KM/H



AUTOMATIC AWD  
TOP SPEED KM/H



AUTOMATIC RWD  
TOP SPEED KM/H



AUTOMATIC RWD  
TOP SPEED KM/H



# 1 CHOOSE YOUR ENGINE

 Configure your vehicle at [jaguar.com](http://jaguar.com)

## > PETROL ENGINES

### 2.0 LITRE 4 CYLINDER TURBOCHARGED

<b>XF SALOON</b>
MAXIMUM POWER 200PS
MAXIMUM TORQUE 320Nm
ACCELERATION 0-100 km/h Automatic RWD 7.5 seconds
TOP SPEED Automatic RWD 235 km/h
COMBINED FUEL CONSUMPTION RWD 6.8 l/100km
COMBINED CO <sub>2</sub> RWD 154 g/km
PURE, PRESTIGE, PORTFOLIO, R-SPORT

### 2.0 LITRE 4 CYLINDER TURBOCHARGED

<b>XF SALOON</b>
MAXIMUM POWER 250PS
MAXIMUM TORQUE 365Nm
ACCELERATION 0-100 km/h Automatic RWD/AWD 6.6 seconds
TOP SPEED Automatic RWD 244 km/h Automatic AWD 237 km/h
COMBINED FUEL CONSUMPTION RWD 6.8 l/100km AWD 6.9 l/100km
COMBINED CO <sub>2</sub> RWD 154 g/km AWD 159 g/km
PURE, PRESTIGE, PORTFOLIO, R-SPORT

<b>XF SPORTBRAKE</b>
MAXIMUM POWER 250PS
MAXIMUM TORQUE 365Nm
ACCELERATION 0-100 km/h Automatic RWD 7.1 seconds
TOP SPEED Automatic RWD 241 km/h
COMBINED FUEL CONSUMPTION RWD 6.8 l/100km
COMBINED CO <sub>2</sub> RWD 155 g/km
PURE, PRESTIGE, PORTFOLIO, R-SPORT



AUTOMATIC RWD  
0-100 KM/H



AUTOMATIC RWD  
TOP SPEED KM/H



AUTOMATIC RWD  
0-100 KM/H



AUTOMATIC RWD  
TOP SPEED KM/H



AUTOMATIC AWD  
0-100 KM/H



AUTOMATIC AWD  
TOP SPEED KM/H



AUTOMATIC RWD  
0-100 KM/H



AUTOMATIC RWD  
TOP SPEED KM/H

Please refer to Technical Specification pages for full fuel consumption figures.  
The figures provided are as a result of official manufacturer's tests in accordance with EU legislation.  
A vehicle's actual fuel consumption may differ from that achieved in such tests and these figures are for comparative purposes only.  
Engine availability is market dependent. Please consult your local Jaguar Retailer for details.

## 2.0 LITRE

4 CYLINDER TURBOCHARGED

XF SALOON

MAXIMUM POWER 300PS

MAXIMUM TORQUE 400Nm

ACCELERATION 0-100 km/h

Automatic RWD 5.9 Automatic AWD 5.8 seconds

TOP SPEED

Automatic RWD/AWD 250 km/h

COMBINED FUEL CONSUMPTION

RWD 6.8 l/100km AWD 7.2 l/100km

COMBINED CO<sub>2</sub> RWD 153 g/km AWD 163 g/km

PURE, PRESTIGE, PORTFOLIO, R-SPORT

## 3.0 LITRE V6

6 CYLINDER SUPERCHARGED

XF SALOON

MAXIMUM POWER 380PS

MAXIMUM TORQUE 450Nm

ACCELERATION 0-100 km/h

Automatic RWD/AWD 5.3 seconds

TOP SPEED

Automatic RWD/AWD 250 km/h

COMBINED FUEL CONSUMPTION

RWD 8.3 l/100km AWD 8.6 l/100km

COMBINED CO<sub>2</sub> RWD 198 g/km AWD 204 g/km

S



AUTOMATIC RWD  
0-100 KM/H



AUTOMATIC AWD  
0-100 KM/H



AUTOMATIC RWD/AWD  
0-100 KM/H



AUTOMATIC RWD  
TOP SPEED KM/H



AUTOMATIC AWD  
TOP SPEED KM/H



AUTOMATIC RWD/AWD  
TOP SPEED KM/H



# 2 CHOOSE YOUR MODEL

 Configure your vehicle at [jaguar.com](http://jaguar.com)

## > LUXURY



### PURE

#### KEY FEATURES

17" alloy wheels (18" alloy wheels on V6 engines and 2.0 litre 4 cylinder 300PS Petrol engine)  
Halogen headlights  
Premium fabric seats  
8-way manual front seats with electric recline  
Gloss Black veneer  
Morse Code Aluminium instrument panel finisher  
All Surface Progress Control (Automatic Transmission only)

#### SPORTBRAKE KEY FEATURES (IN ADDITION TO SALOON)

Integrated Roof Rails  
Integrated Roof Spoiler  
Rear Self Levelling Air Suspension  
Automatic Loadspace Cover  
40:20:40 Split fold Rear seats  
Powered Tailgate  
Stainless steel loadspace scuff plate



### PRESTIGE

#### KEY FEATURES (IN ADDITION TO PURE)

Bi-functional Xenon headlights with LED 'J' blade Daytime Running Lights and power wash  
Grained leather seats  
10-way electric front seats  
Rear armrest with cupholders\*  
Soft grain leather sport steering wheel  
Carpet mats  
Interior mood lighting

#### SPORTBRAKE KEY FEATURES (IN ADDITION TO SALOON)

Integrated Roof Rails  
Integrated Roof Spoiler  
Rear Self Levelling Air Suspension  
Automatic Loadspace Cover  
40:20:40 Split fold Rear seats  
Powered Tailgate  
Stainless steel loadspace scuff plate



### PORTFOLIO

#### KEY FEATURES (IN ADDITION TO PRESTIGE)

18" alloy wheels (17" alloy wheels on 2.0 litre 4 cylinder 163PS Diesel engine)  
Windsor leather seats  
Windsor leather instrument panel finisher  
Gloss Figured Ebony veneer

#### SPORTBRAKE KEY FEATURES (IN ADDITION TO SALOON)

Integrated Roof Rails  
Integrated Roof Spoiler  
Rear Self Levelling Air Suspension  
Automatic Loadspace Cover  
40:20:40 Split fold Rear seats  
Powered Tailgate  
Stainless steel loadspace scuff plate

\*Standard on all XF Sportbrake models. \*\*XF Saloon only. †Boot mounted spoiler only available on XF Saloon.

Images feature optional equipment. Please note that standard features may be replaced when selecting alternative trim levels.

Standard features may also vary depending on country of purchase, engine variant and transmission, please refer to Specification and Price Guide or website for your local market.

## > SPORT



### R-SPORT

#### KEY FEATURES (IN ADDITION TO PRESTIGE)

18" alloy wheels (17" alloy wheels on 2.0 litre 4 cylinder 163PS Diesel engine)

R-Sport body kit including sports front bumper, side sills and boot mounted spoiler†

Sports suspension (only available on Ingenium 2.0 litre Petrol 200PS\*\* and 250PS RWD engines and Ingenium Diesel 180PS and 240PS\*\* RWD engines)

Sports grained leather seats with Technical Mesh inserts

Metal treadplates and multi-function steering wheel with R-Sport branding

Gloss Black side window surround

Dark Morse Code Aluminium instrument panel finisher

#### SPORTBRAKE KEY FEATURES (IN ADDITION TO SALOON)

Gloss Black Roof Rails

Integrated Roof Spoiler

Rear Self Levelling Air Suspension

Automatic Loadspace Cover

40:20:40 Split fold Rear seats

Powered Tailgate

Stainless steel loadspace scuff plate



### S

#### KEY FEATURES (IN ADDITION TO R-SPORT)

19" alloy wheels

S body kit including sports front bumper, Gloss Black side sills, rear valance and boot mounted spoiler†

Red brake calipers

Sports grained leather S embossed seats with suedecloth inserts

Grey Figured Ebony veneer

Dark Hex Aluminium instrument panel finisher

Bright sport pedals

Metal treadplates and multi-function steering wheel with S branding

Adaptive Dynamics

#### SPORTBRAKE KEY FEATURES (IN ADDITION TO SALOON)

Gloss Black Roof Rails

Integrated Roof Spoiler

Rear Self Levelling Air Suspension

Automatic Loadspace Cover

40:20:40 Split fold Rear seats

Powered Tailgate

Stainless steel loadspace scuff plate



# 3 CHOOSE YOUR COLOUR

 [Configure your vehicle at jaguar.com](https://www.jaguar.com)

## SOLID

Fuji White

Narvik Black

## METALLIC

Yulong White

Santorini Black

Indus Silver

Corris Grey

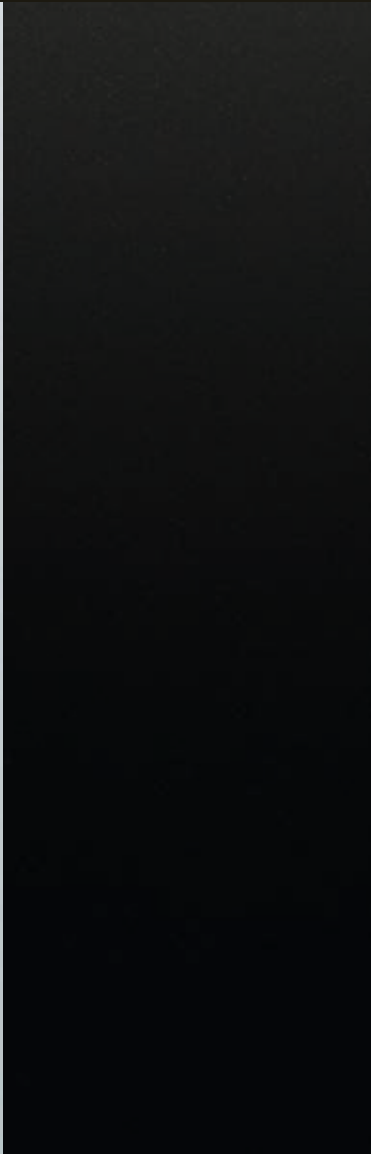
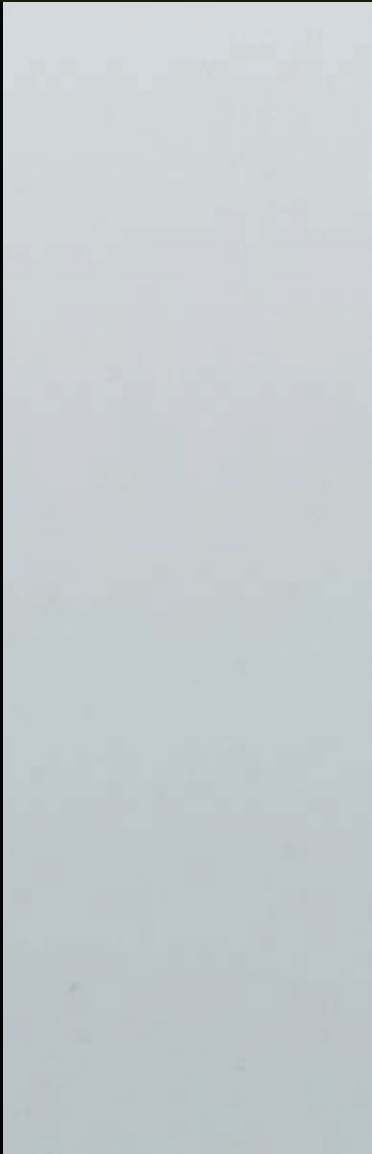
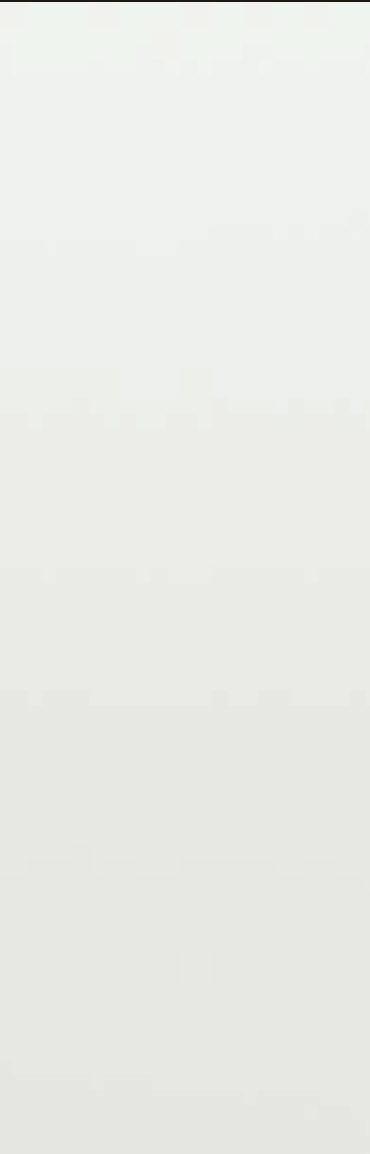

PREMIUM PALETTE

Loire Blue



Caesium Blue

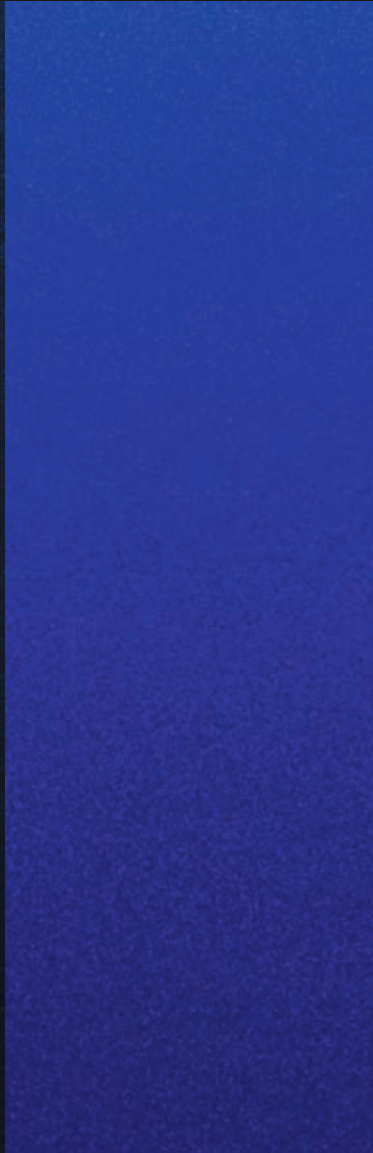

Firenze Red



Rossello Red



Carpathian Grey

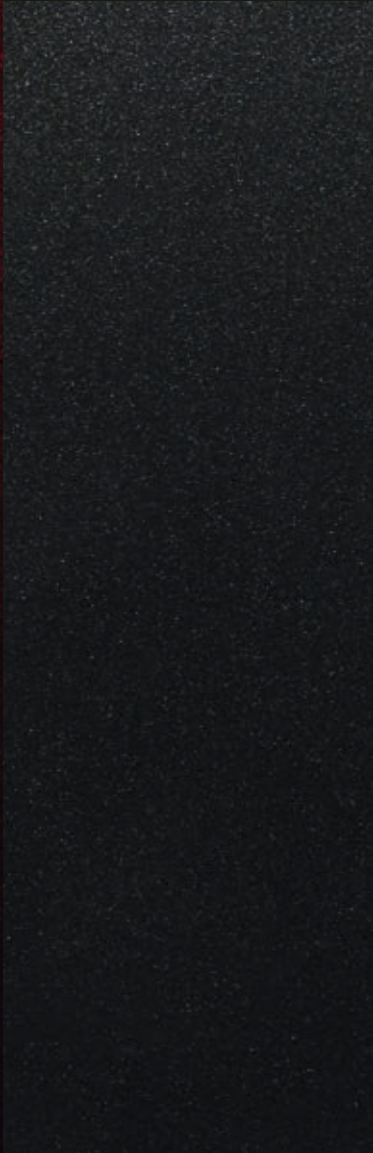

Silicon Silver





# 4 CHOOSE YOUR WHEELS

 Configure your vehicle at [jaguar.com](http://jaguar.com)



17" 10 SPOKE  
'STYLE 1017'



17" 15 SPOKE  
'STYLE 1016'



17" 9 SPOKE  
'STYLE 9005'



18" 5 SPOKE  
'STYLE 5034'



18" 7 SPLIT-SPOKE  
'STYLE 7011'

ALLOY WHEEL FINISH	Silver	Silver	Silver	Silver	Silver
ALLOY WHEEL/SIZE	7.5J x 17"	7.5J x 17"	7.5J x 17"	8.0J x 18"	8.0J x 18"
TYRE SIZE	225/55 R17	225/55 R17	225/55 R17	245/45 R18	245/45 R18
CODE	C54A	C54B	C54C	C53R	C53S



18" 5 SPLIT-SPOKE  
'STYLE 5033'



18" 5 SPLIT-SPOKE  
'STYLE 5033'



18" 5 SPLIT-SPOKE  
'STYLE 5033'



19" 7 SPLIT-SPOKE  
'STYLE 7012'



19" 7 SPLIT-SPOKE  
'STYLE 7013'

ALLOY WHEEL FINISH	Silver	Contrast/Diamond Turned	Gloss Black	Silver	Silver
ALLOY WHEEL/SIZE	8.0J x 18"	8.0J x 18"	8.0J x 18"	8.0J x 19"	8.0J x 19"
TYRE SIZE	245/45 R18	245/45 R18	245/45 R18	245/40 R19	245/40 R19
CODE	C53T	C53P	C530	C53U	C53V

Wheel availability is market dependent. Please consult your local Jaguar Retailer for details.



19" 7 SPLIT-SPOKE  
'STYLE 7013'



19" 10 SPOKE  
'STYLE 1018'



19" 5 SPOKE  
'STYLE 5035'



19" 5 SPOKE  
'STYLE 5035'



20" 9 SPLIT-SPOKE  
'STYLE 9004'

ALLOY WHEEL FINISH	Contrast/Diamond Turned	Silver	Gloss Dark Grey/Diamond Turned	Gloss Black	Silver
ALLOY WHEEL/SIZE	8.0J x 19"	8.0J x 19"	8.0J x 19"	8.0J x 19"	8.5J x 20"
TYRE SIZE	245/40 R19	245/40 R19	245/40 R19	245/40 R19	255/35 R20
CODE	C53Z	C53W	C53Y	C53X	C53H



20" 9 SPLIT-SPOKE  
'STYLE 9004'



20" 5 SPLIT-SPOKE  
'STYLE 5071'



20" 5 SPLIT-SPOKE  
'STYLE 5031'



20" 5 SPLIT-SPOKE  
'STYLE 5031'



20" 5 SPLIT-SPOKE  
'STYLE 5036'

ALLOY WHEEL FINISH	Contrast/Diamond Turned	Silver	Gloss Dark Grey/Diamond Turned	Gloss Black	Gloss Dark Grey/Diamond Turned
ALLOY WHEEL/SIZE	8.5J x 20"	8.5J x 20"	8.5J x 20"	8.5J x 20"	8.5J x 20"
TYRE SIZE	255/35 R20	255/35 R20	255/35 R20	255/35 R20	255/35 R20
CODE	C53J	C53K	C53F	C53L	C53G

Standard and optional features may differ depending on market availability. On XF Sportbrake, 19" is the maximum wheel size permissible for the fitment of Detachable tow bar (C05C) and Electrically deployable tow bar (C05B).



# 5 CHOOSE YOUR INTERIOR

 Configure your vehicle at [jaguar.com](http://jaguar.com)

PURE						
	SEAT WITH TONAL STITCH	UPPER FACIA WITH TONAL STITCH	INTERIOR TRIM AND OPTION CODES	HEADLINING MORZINE	CARPET	VENEER
Premium fabric seats (EU only)	Ebony with Ebony	Ebony with Ebony	TR23	Ebony or Light Oyster	Ebony	Gloss Black
	Latte with Latte	Espresso with Espresso	TR24	Light Oyster	Espresso	Gloss Black
Luxtec seats*	Ebony with Ebony	Ebony with Ebony	TR23	Ebony or Light Oyster	Ebony	Gloss Black
	Latte with Latte	Espresso with Espresso	TR24	Light Oyster	Espresso	Gloss Black
	Light Oyster with Light Oyster	Oyster with Oyster	TR25	Light Oyster	Oyster	Gloss Black
PRESTIGE						
	SEAT WITH TONAL STITCH	UPPER FACIA WITH TONAL STITCH	INTERIOR TRIM AND OPTION CODES	HEADLINING MORZINE	CARPET	VENEER
Grained leather seats	Ebony with Ebony	Ebony with Ebony	TR26	Ebony or Light Oyster	Ebony	Gloss Black
	Latte with Latte	Espresso with Espresso	TR27	Light Oyster	Espresso	Gloss Black
	Light Oyster with Light Oyster	Oyster with Oyster	TR28	Light Oyster	Oyster	Gloss Black
PORTFOLIO						
	SEAT WITH TONAL STITCH	UPPER FACIA WITH TONAL STITCH	INTERIOR TRIM AND OPTION CODES	HEADLINING MORZINE	CARPET	VENEER
Windsor leather seats	Ebony with Ebony	Ebony with Ebony	TR37	Ebony or Light Oyster	Ebony	Gloss Figured Ebony
	Latte with Latte	Espresso with Espresso	TR38	Light Oyster	Espresso	Gloss Figured Ebony
	Light Oyster with Light Oyster	Oyster with Oyster	TR39	Light Oyster	Oyster	Gloss Figured Ebony
	Espresso with Espresso	Espresso with Espresso	TR40	Light Oyster	Espresso	Gloss Figured Ebony
	Siena Tan with Siena Tan	Ebony with Ebony	TR41	Ebony or Light Oyster	Ebony	Gloss Figured Ebony

\*XF Saloon only.

Standard and optional features may differ depending on market availability. Please consult your local Jaguar Retailer for details.

<b>R-SPORT</b>						
	<b>DUO TONE SEAT WITH CONTRAST STITCH</b>	<b>UPPER FACIA WITH CONTRAST STITCH</b>	<b>INTERIOR TRIM AND OPTION CODES</b>	<b>HEADLINING MORZINE</b>	<b>CARPET</b>	<b>VENEER</b>
Sports grained leather seats with Technical Mesh inserts	Ebony/Ebony with Light Oyster	Ebony with Light Oyster	TR29	Ebony or Light Oyster	Ebony	Gloss Black
Grained leather sports seats	Ebony/Ebony with Light Oyster	Ebony with Light Oyster	TR29 + B41T	Ebony or Light Oyster	Ebony	Gloss Black
	Ebony/Pimento with Pimento	Ebony with Pimento	TR30 + B41T	Ebony or Light Oyster	Ebony	Gloss Black
	Ebony/Light Oyster with Light Oyster	Ebony with Light Oyster	TR31 + B41T	Ebony or Light Oyster	Ebony	Gloss Black
	Brogue/Brogue with Light Oyster	Ebony with Light Oyster	TR32 + B41T	Ebony or Light Oyster	Ebony	Gloss Black

<b>S</b>						
	<b>DUO TONE SEAT WITH CONTRAST STITCH</b>	<b>UPPER FACIA WITH CONTRAST STITCH</b>	<b>INTERIOR TRIM AND OPTION CODES</b>	<b>HEADLINING MORZINE</b>	<b>CARPET</b>	<b>VENEER</b>
Sports grained leather seats with suedecloth inserts	Ebony/Ebony with Light Oyster	Ebony with Light Oyster	TR33	Ebony or Light Oyster	Ebony	Grey Figured Ebony
	Pimento/Ebony with Ebony	Ebony with Pimento	TR34	Ebony or Light Oyster	Ebony	Grey Figured Ebony
Grained leather sports seats	Ebony/Ebony with Light Oyster	Ebony with Light Oyster	TR33 + B41T	Ebony or Light Oyster	Ebony	Grey Figured Ebony
	Pimento/Ebony with Ebony	Ebony with Pimento	TR34 + B41T	Ebony or Light Oyster	Ebony	Grey Figured Ebony
	Light Oyster/Ebony with Ebony	Ebony with Light Oyster	TR35 + B41T	Ebony or Light Oyster	Ebony	Grey Figured Ebony
	Brogue/Brogue with Light Oyster	Ebony with Light Oyster	TR36 + B41T	Ebony or Light Oyster	Ebony	Grey Figured Ebony



# 5 CHOOSE YOUR INTERIOR

⚙️ Configure your vehicle at [jaguar.com](https://www.jaguar.com)

Interior shown: Ebony fabric seats with Ebony facia, Morse Code Aluminium finisher, Gloss Black veneer and optional Ebony headlining.



# PURE

## INTERIOR COLOUR COMBINATIONS

①	②	③	④	⑤	⑥
SEAT WITH TONAL STITCH	VENEER	HEADLINING MORZINE	UPPER FACIA WITH TONAL STITCH	FINISHER	CARPETS
					
Ebony	Gloss Black	Ebony or Light Oyster	Ebony with Ebony	Morse Code Aluminium	Ebony
					
Latte	Gloss Black	Light Oyster	Espresso with Espresso	Morse Code Aluminium	Espresso

### VENEER OPTIONS

Carbon Fibre Veneer, Satin Burr Ash Veneer, Gloss Figured Ebony Veneer, Grey Figured Ebony Veneer, Satin Fine Line Veneer, Satin Rosewood Veneer or Gloss Burr Walnut Veneer

Standard and optional features may differ depending on market availability. Please consult your local Jaguar Retailer for details.



# 5 CHOOSE YOUR INTERIOR

⚙️ Configure your vehicle at [jaguar.com](https://www.jaguar.com)













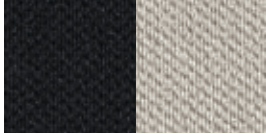





Interior shown: Ebony grained leather seats with Ebony tonal stitch, Ebony facia, Morse Code Aluminium finisher, Gloss Black veneer and optional Ebony headlining.





# PRESTIGE

## INTERIOR COLOUR COMBINATIONS

1	2	3	4	5	6
SEAT WITH TONAL STITCH	veneer	HEADLINING MORZINE	UPPER FACIA WITH TONAL STITCH	FINISHER	CARPETS
					
Ebony with Ebony	Gloss Black	Ebony or Light Oyster	Ebony with Ebony	Morse Code Aluminium	Ebony
					
Latte with Latte	Gloss Black	Light Oyster	Espresso with Espresso	Morse Code Aluminium	Espresso
					
Light Oyster with Light Oyster	Gloss Black	Light Oyster	Oyster with Oyster	Morse Code Aluminium	Oyster

### VENEER OPTIONS

Carbon Fibre Veneer, Satin Burr Ash Veneer, Gloss Figured Ebony Veneer, Grey Figured Ebony Veneer, Satin Fine Line Veneer, Satin Rosewood Veneer or Gloss Burr Walnut Veneer

Standard and optional features may differ depending on market availability. Please consult your local Jaguar Retailer for details.

# 5 CHOOSE YOUR INTERIOR











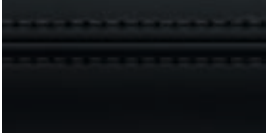

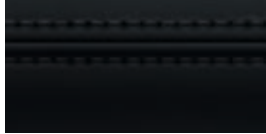















⚙️ Configure your vehicle at [jaguar.com](https://www.jaguar.com)

Interior shown: Latte Windsor leather seats with Latte tonal stitch, Espresso facia, Morse Code Aluminium finisher, Gloss Figured Ebony veneer and Light Oyster headlining.

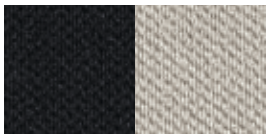

# PORTFOLIO

## INTERIOR COLOUR COMBINATIONS

1	2	3	4	5	6
SEAT WITH TONAL STITCH	veneer	HEADLINING MORZINE	UPPER FACIA WITH TONAL STITCH	FINISHER	CARPETS
					
Ebony with Ebony	Gloss Figured Ebony	Ebony or Light Oyster	Ebony with Ebony	Morse Code Aluminium	Ebony
					
Latte with Latte	Gloss Figured Ebony	Light Oyster	Espresso with Espresso	Morse Code Aluminium	Espresso
					
Light Oyster with Light Oyster	Gloss Figured Ebony	Light Oyster	Oyster with Oyster	Morse Code Aluminium	Oyster
					
Espresso with Espresso	Gloss Figured Ebony	Light Oyster	Espresso with Espresso	Morse Code Aluminium	Espresso
					
Siena Tan with Siena Tan	Gloss Figured Ebony	Ebony or Light Oyster	Ebony with Ebony	Morse Code Aluminium	Ebony

### VENEER OPTIONS

Gloss Black Veneer, Carbon Fibre Veneer, Satin Ash Burr Veneer, Grey Figured Ebony Veneer, Satin Fine Line Veneer, Satin Rosewood Veneer or Gloss Burr Walnut Veneer

Standard and optional features may differ depending on market availability. Please consult your local Jaguar Retailer for details.



# 5 CHOOSE YOUR INTERIOR

⚙️ Configure your vehicle at [jaguar.com](https://www.jaguar.com)

Interior shown: Ebony grained leather sports seats with Ebony Technical Mesh inserts and Light Oyster contrast stitch, Ebony facia with Light Oyster contrast stitch, Dark Morse Code Aluminium finisher, Gloss Black veneer and optional Light Oyster headlining.



# R-SPORT

## INTERIOR COLOUR COMBINATIONS

1

DUO TONE SEAT WITH  
CONTRAST STITCH

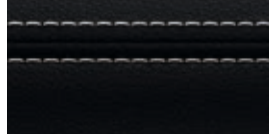

Ebony/Ebony with Light Oyster

2

VENEER



Gloss Black

3

HEADLINING MORZINE

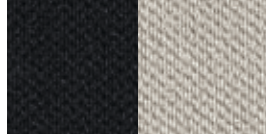

Ebony or Light Oyster

4

UPPER FACIA WITH  
CONTRAST STITCH

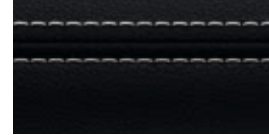

Ebony with Light Oyster

5

FINISHER



Dark Morse Code Aluminium

6

CARPETS



Ebony

### VENEER OPTIONS

Carbon Fibre Veneer, Satin Ash Burr Veneer, Gloss Figured Ebony Veneer, Grey Figured Ebony Veneer, Satin Fine Line Veneer, Satin Rosewood Veneer or Gloss Burr Walnut Veneer

Standard and optional features may differ depending on market availability.  
Please consult your local Jaguar Retailer for details.

# 5 CHOOSE YOUR INTERIOR

⚙️ Configure your vehicle at [jaguar.com](http://jaguar.com)





















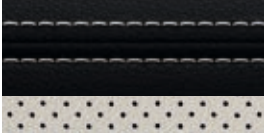

Interior shown: Ebony and Light Oyster perforated grained leather sports seats with Light Oyster contrast stitch, Ebony facia with Light Oyster contrast stitch, Dark Morse Code Aluminium finisher, optional Satin Fine Line veneer and optional Light Oyster headlining.



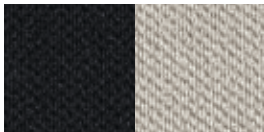
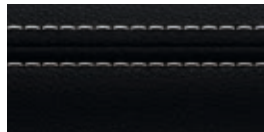

# R-SPORT

## INTERIOR COLOUR COMBINATIONS

1	2	3	4	5	6
<p>DUO TONE SEAT WITH CONTRAST STITCH</p>  <p>Ebony/Ebony with Light Oyster</p>	<p>VENEER</p>  <p>Gloss Black</p>	<p>HEADLINING MORZINE</p>  <p>Ebony or Light Oyster</p>	<p>UPPER FACIA WITH CONTRAST STITCH</p>  <p>Ebony with Light Oyster</p>	<p>FINISHER</p>  <p>Dark Morse Code Aluminium</p>	<p>CARPETS</p>  <p>Ebony</p>
 <p>Ebony/Pimento with Pimento</p>	 <p>Gloss Black</p>	 <p>Ebony or Light Oyster</p>	 <p>Ebony with Pimento</p>	 <p>Dark Morse Code Aluminium</p>	 <p>Ebony</p>
 <p>Ebony/Light Oyster with Light Oyster</p>	 <p>Gloss Black</p>	 <p>Ebony or Light Oyster</p>	 <p>Ebony with Light Oyster</p>	 <p>Dark Morse Code Aluminium</p>	 <p>Ebony</p>
 <p>Brogue/Brogue with Light Oyster</p>	 <p>Gloss Black</p>	 <p>Ebony or Light Oyster</p>	 <p>Ebony with Light Oyster</p>	 <p>Dark Morse Code Aluminium</p>	 <p>Ebony</p>

### VENEER OPTIONS

Carbon Fibre Veneer, Satin Ash Burr Veneer, Gloss Figured Ebony Veneer, Grey Figured Ebony Veneer, Satin Fine Line Veneer, Satin Rosewood Veneer or Gloss Burr Walnut Veneer

Standard and optional features may differ depending on market availability. Please consult your local Jaguar Retailer for details.

# 5 CHOOSE YOUR INTERIOR

⚙️ Configure your vehicle at [jaguar.com](https://www.jaguar.com)

Interior shown: Ebony grained leather sports seats with Ebony suedecloth inserts and Light Oyster contrast stitch, Ebony fascia with Light Oyster contrast stitch, Dark Hex Aluminium finisher, Grey Figured Ebony veneer and Ebony headlining.



# S

## INTERIOR COLOUR COMBINATIONS

1

DUO TONE SEAT WITH  
CONTRAST STITCH

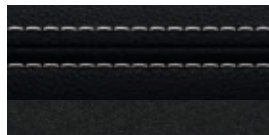

Ebony/Ebony with Light Oyster



Pimento/Ebony with Ebony

2

VENEER



Grey Figured Ebony



Grey Figured Ebony

3

HEADLINING MORZINE

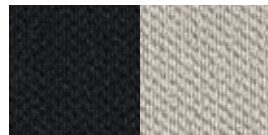

Ebony or Light Oyster

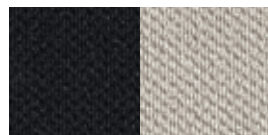

Ebony or Light Oyster

4

UPPER FACIA WITH  
CONTRAST STITCH



Ebony with Light Oyster



Ebony with Pimento

5

FINISHER



Dark Hex Aluminium



Dark Hex Aluminium

6

CARPETS



Ebony



Ebony

### VENEER OPTIONS

Gloss Black Veneer, Carbon Fibre Veneer, Satin Ash Burr Veneer, Gloss Figured Ebony Veneer, Satin Fine Line Veneer, Satin Rosewood Veneer or Gloss Burr Walnut Veneer

Standard and optional features may differ depending on market availability.  
Please consult your local Jaguar Retailer for details.



# 5 CHOOSE YOUR INTERIOR

⚙️ Configure your vehicle at [jaguar.com](https://www.jaguar.com)

Interior shown: Light Oyster and Ebony perforated grained leather sports seats with Ebony contrast stitch, Ebony fascia with Light Oyster contrast stitch, Dark Hex Aluminium finisher, Grey Figured Ebony veneer and Ebony headlining.



# S

## INTERIOR COLOUR COMBINATIONS

1

DUO TONE SEAT WITH  
CONTRAST STITCH



Ebony/Ebony with Light Oyster

2

VENEER



Grey Figured Ebony

3

HEADLINING MORZINE



Ebony or Light Oyster

4

UPPER FACIA WITH  
CONTRAST STITCH



Ebony with Light Oyster

5

FINISHER



Dark Hex Aluminium

6

CARPETS



Ebony



Pimento/Ebony with Ebony



Grey Figured Ebony

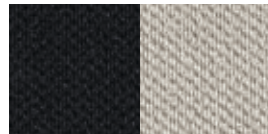

Ebony or Light Oyster



Ebony with Pimento



Dark Hex Aluminium



Ebony



Light Oyster/Ebony with Ebony



Grey Figured Ebony

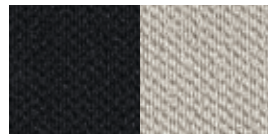

Ebony or Light Oyster

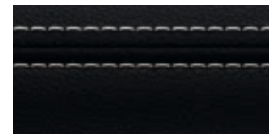

Ebony with Light Oyster



Dark Hex Aluminium



Ebony



Brogue/Brogue with Light  
Oyster

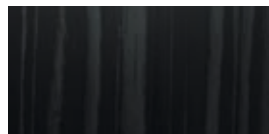

Grey Figured Ebony

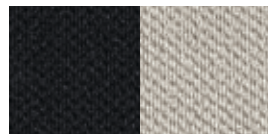

Ebony or Light Oyster

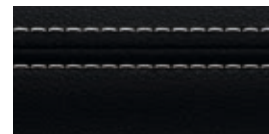

Ebony with Light Oyster



Dark Hex Aluminium



Ebony

### VENEER OPTIONS

Gloss Black Veneer, Carbon Fibre Veneer, Satin Ash Burr Veneer, Gloss Figured Ebony Veneer, Satin Fine Line Veneer, Satin Rosewood Veneer or Gloss Burr Walnut Veneer

Standard and optional features may differ depending on market availability.  
Please consult your local Jaguar Retailer for details.



# 5 CHOOSE YOUR INTERIOR

 Configure your vehicle at [jaguar.com](https://www.jaguar.com)

Gloss Black Veneer

Carbon Fibre Veneer

Satin Ash Burr Veneer

Gloss Figured Ebony Veneer





Grey Figured Ebony Veneer



Satin Fine Line Veneer



Satin Rosewood Veneer



Gloss Burr Walnut Veneer

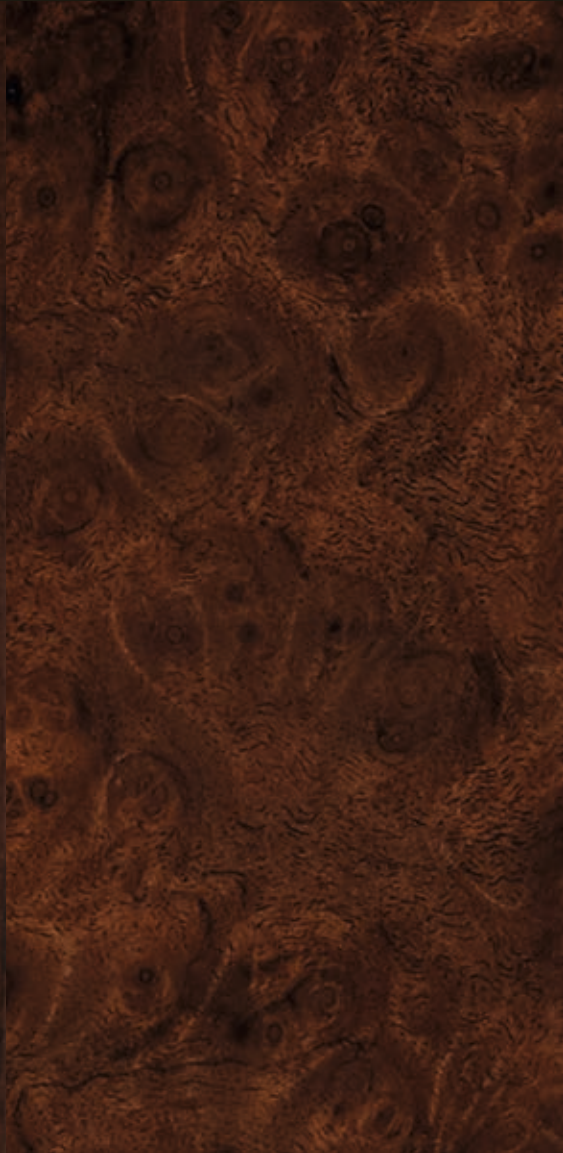

# 6 CHOOSE YOUR JAGUAR GEAR

The genuine range of accessories from Jaguar.

 Configure your vehicle at [jaguar.com](https://www.jaguar.com)



## **Watersports Carrier\*** **C2Z21730**

A versatile system for transporting a variety of water sports equipment including surfboard, kayak or sailboard. Tilts to facilitate loading/unloading.

\*Requires roof cross bars T2H14468. \*\*Not available for Pure.

Accessory availability is market dependent. Please consult your local Jaguar Retailer for details.

VEHICLE SHOWN: XF SALOON S IN YULONG WHITE WITH OPTIONAL FEATURES FITTED (MARKET DEPENDENT)





**Aluminium Paddle Shifters**  
**T2R6547 Automatic transmission only.**  
**T2R6547CAY Red. Automatic transmission only.**

Replacement steering wheel gearshift paddles offered in a premium aluminium material providing a high quality finish to a key contact point in the vehicle. Manufactured from billet machined aluminium, the paddles are hand brushed for a premium finish and anodised to ensure they will not deteriorate with wear.



**Premium Carpet Mats**  
**T2H7171PVJ - LHD**  
**T2H7173 - LHD AWD**

Luxurious, tailored 2,050g/m<sup>2</sup> pile front carpet mats with embossed Jaguar logo and Nubuck edge binding. The premium mats provide a well appointed finishing touch to the interior.



**Central Armrest Chiller/Warmer**  
**T2H7739**

Food and drinks chiller and warmer that acts as a rear centre armrest. With a leather-covered top, it is held in place by the centre seat belt and powered from the rear auxiliary socket. Ideal for long journeys with the family.



**iPad Holder**  
**T2H7757**

Jaguar branded iPad® holder mounts to front seat headrests providing a flexible solution for rear seat entertainment. Quick release design ensures iPad® can be fitted or removed quickly and easily.



**Personalised Illuminated Sill Treadplates\*\***  
**T2H17122PVJ**

Elegantly styled stainless steel sill treadplate finishers for driver or passenger doors. Illuminates when either the driver or passenger doors are opened. Highlighted by soft Phosphor Blue lighting. Allows you to specify a monochrome 'motif' in a choice of approved typefaces/scripts.



**Rubber Mats**  
**T4N7742 - LHD**  
**T2H7743 - LHD AWD**

Hard wearing Jaguar branded rubber mats provide added protection for your vehicle's carpets.



# 6 CHOOSE YOUR JAGUAR GEAR

 Configure your vehicle at [jaguar.com](http://jaguar.com)



**Gloss Black Side Vent\***  
T4N5176 - Left Side  
T4N5178 - Right Side

Jaguar branded, Gloss Black side power vents provide a dynamic exterior styling enhancement.



**Carbon Fibre Side Vent**  
T2H18318 - Left Side  
T2H18319 - Right Side

High grade Carbon Fibre side power vents provide a performance-inspired styling upgrade.



**Noble Chrome Mirror Caps**  
T2H26929

Chrome mirror covers accentuate the stylish design of the exterior mirrors.



**Gloss Black Mirror Cap**  
C2D6067PEC - Left Side  
C2D6066PEC - Right Side

Gloss Black mirror covers accentuate the dynamic design of the exterior mirrors.



**Carbon Fibre Mirror Cap**  
C2P24176 - Right Side  
C2P24177 - Left Side

High grade Carbon Fibre mirror covers provide a performance-inspired styling upgrade.



**Rear Tailgate Trim - Gloss Black†**  
T2H17748

Add style and visual distinction with Gloss Black finish rear tailgate trim.

\*Not applicable for R-Sport. \*\*Requires roof cross bars T2H14468. †Only available on XF Saloon.  
Accessory availability is market dependent. Please consult your local Jaguar Retailer for details.



**Roof Cross Bars†**  
**T2H14468**

Jaguar branded cross bars required for fitting all roof carrying equipment. Engineered specifically for your vehicle.



**Roof Luggage Box\*\***  
**C2C41628**

Spacious 410 litre capacity lockable roof luggage box, measuring 175 x 82 x 45cm.



**Roof Sport Box\*\***  
**C2C41627**

Spacious 320 litre capacity lockable roof box designed for sports equipment, measuring 206 x 84 x 34cm.



**Ski/Snowboard Holder\*\***  
**C2A1538**

A safe and secure Jaguar branded system for transporting winter sports equipment. Incorporates slider rails for easy loading. For four pairs of skis or two snowboards.



**Fork Mounted Cycle Carrier\*\***  
**C2A1540**

Fitted to the roof, the fork mounted cycle carrier provides a simple and secure fitting with the bike front wheel removed, ideally suited to lightweight bikes and 'racing' wheels. A separate carrier is included for the front wheel. Easy to fit, lockable cycle carrier which carries one bike per holder. A maximum of three holders can be fitted.



**Tow Bar Mounted Cycle Carrier**  
**C2Z22695 - 2 Bike**  
**C2Z22697 - 3 Bike**

Premium tow ball mounted cycle carriers provide a convenient bike carrying solution with quick release loading attachments and secure locking mechanism. Clever design allows carrier to be tilted away from vehicle when fitted allowing access into the rear tailgate.

# 6 CHOOSE YOUR JAGUAR GEAR

 Configure your vehicle at [jaguar.com](http://jaguar.com)



## **Roof Mounted Cycle Carrier\*** **C2A1539**

An easy to fit, roof mounted, lockable cycle carrier which carries one bike per holder. A maximum of three holders can be fitted.

\*Requires roof cross bars T2H24300. \*\*Only available on XF Sportbrake.

Accessory availability is market dependent. Please consult your local Jaguar Retailer for details.

VEHICLE SHOWN: XF SPORTBRAKE S IN YULONG WHITE WITH OPTIONAL FEATURES FITTED (MARKET DEPENDENT)





**Roof Cross Bars\*\***  
**T2H24300**

Jaguar branded cross bars required for fitting all roof carrying equipment. Engineered specifically for your vehicle.



**Roof Sport Box\***  
**C2C41627**

Spacious 320 litre capacity lockable roof box designed for sports equipment, measuring 206 x 84 x 34cm.



**Fork Mounted Cycle Carrier\***  
**C2A1540**

Fitted to the roof, the fork mounted cycle carrier provides a simple and secure fitting with the bike front wheel removed, ideally suited to lightweight bikes and 'racing' wheels. A separate carrier is included for the front wheel. Easy to fit, lockable cycle carrier which carries one bike per holder. A maximum of three holders can be fitted.



**Watersports Carrier\***  
**C2Z21730**

A versatile system for transporting a variety of water sports equipment including surfboard, kayak or sailboard. Tilts to facilitate loading/unloading.



**Ski/Snowboard Holder\***  
**C2A1538**

A safe and secure Jaguar branded system for transporting winter sports equipment. Incorporates slider rails for easy loading. For four pairs of skis or two snowboards.



**Tow Bar Mounted Cycle Carrier**  
**C2Z22695 - 2 Bike**  
**C2Z22697 - 3 Bike**

Premium tow ball mounted cycle carriers provide a convenient bike carrying solution with quick release loading attachments and secure locking mechanism. Clever design allows carrier to be tilted away from vehicle when fitted allowing access into the rear tailgate.

# 6 CHOOSE YOUR JAGUAR GEAR

 Configure your vehicle at [jaguar.com](http://jaguar.com)



**Click and Play - iPad\* 2-4\***  
**J9C2163**

Click and Play is a removable tablet holder attachment which is available for various tablets, and can be easily positioned in multiple angles for in cabin comfort and rear entertainment.



**Click and Hook\***  
**J9C2169**

Click and Hook is a universal hook that creates extra storage space for items to be hung.



**Click and Hang\***  
**J9C2167**

Click and Hang is a removable coat hanger allowing for shirts and jackets to be kept crease-free whilst transporting.



**Union Jack Sill Treadplates**  
**T2H17123PVJ - Ebony**  
**T2H17123AMT - Oyster**

Elegantly styled stainless steel sill treadplate finisher for driver or passenger doors featuring a distinctly British design.

\*Only available on XF Sportbrake.

Accessory availability is market dependent. Please consult your local Jaguar Retailer for details.



**Sport Pedal Covers**  
**T2H3747 - Manual**  
**T2H3746 - Automatic (not shown)**

Made from stainless steel and rubber, the pedal kit fits securely over existing pedals for a contemporary, sporting appearance. Standard on 'S'.



**Luggage Compartment Waterproof Liner\***  
**T2H24704**

Total protection for the luggage compartment and second row seat back. Bespoke developed for XF Sportbrake, the liner is fully waterproof and is easy to fit or remove in a matter of minutes.



**Aperture Retention Net\***  
**T2H31242**

The aperture retention net prevents small items from falling out of the loadspace when the tailgate is opened and maximises packing space. Manufactured from premium lightweight materials including high grade machined aluminium to ensure robust quality.



**Luggage Guard\***  
**T2H31273**

The luggage compartment partition is designed to prevent cargo from entering the passenger compartment.



**Luggage Compartment Collapsible Organiser\***  
**T2H7752**

Collapsible luggage compartment organiser keeps items from shifting during transport with two durable straps.



**Luggage Compartment Rubber Mat\***  
**T2H24552**

This premium mat is tailored specifically to protect the luggage compartment. Light and durable, it is easily removable for cleaning.



**Luggage Compartment Multi-purpose Liner\***  
**T2H24651**

All-in-one premium loadspace carpet mat and double layer reversible rubber liner helps protect the rear loadspace area from general dirt. The liner can be folded out to cover the back of the second row seats when folded down. Also includes fold out bumper protector.



**Bumper Protector\***  
**T2H24701**

Provides protection for the rear bumper from scuffs and scratches and helps to prevent clothing from collecting dirt when loading and unloading.



# TECHNICAL SPECIFICATIONS

 Configure your vehicle at [jaguar.com](http://jaguar.com)

ENGINES		E-PERFORMANCE 2.0 LITRE 4 CYLINDER TURBOCHARGED DIESEL		20d 2.0 LITRE 4 CYLINDER TURBOCHARGED DIESEL	
Capacity	cc	1,999		1,999	
Maximum power	EEC-PS (kW)	163 (120)		180 (132)	
@rev/min	rpm	4,000		4,000	
Maximum torque	EEC-Nm (lb.ft.)	380 (280)		430 (318)	
@rev/min	rpm	1,750-2,500		1,750-2,500	

PERFORMANCE		XF SALOON		XF SPORTBRAKE		XF SALOON		XF SPORTBRAKE
		MANUAL RWD	AUTO RWD	MANUAL RWD	AUTO RWD	MANUAL RWD	AUTO RWD/AWD	AUTO RWD/AWD
0-100 km/h	seconds	8.7	8.7	9.3	9.4	8.0	8.1/8.4	8.8/8.9
0-60 mph	seconds	8.2	8.2	8.6	8.7	7.5	7.7/7.9	8.2/8.3
Top speed	km/h (mph)	229 (142)	227 (141)	219 (136)	219 (136)	230 (143)	229 (142)/222 (138)	221 (138)/219 (136)

FUEL CONSUMPTION <sup>1</sup>		XF SALOON		XF SPORTBRAKE		XF SALOON		XF SPORTBRAKE
		MANUAL RWD	AUTO RWD	MANUAL RWD	AUTO RWD	MANUAL RWD	AUTO RWD/AWD	AUTO RWD/AWD
Urban	l/100km (mpg)	4.8 (58.9)	5.1 (55.4)	5.6 (50.4)	5.7 (49.6)	5.1 (55.4)	5.2 (54.3)/5.7 (49.6)	5.5 (51.4) <sup>2</sup> /5.8 (48.7)
Extra Urban	l/100km (mpg)	3.6 (78.5)	3.6 (78.5)	3.9 (72.4)	3.8 (74.3)	3.9 (72.4)	3.8 (74.3)/4.5 (62.8)	4.1 (68.9) <sup>3</sup> /4.6 (62.1)
Combined	l/100km (mpg)	4.0 (70.6)	4.1 (68.9)	4.5 (62.8)	4.5 (62.8)	4.3 (65.7)	4.3 (65.7)/4.9 (57.7)	4.6 (61.4) <sup>4</sup> /5.0 (56.5)
CO <sub>2</sub> Urban	g/km	124	133	147	149	132	136/149	143/153
CO <sub>2</sub> Extra Urban	g/km	94	94	101	101	102	100/117	107 <sup>5</sup> /120
CO <sub>2</sub> Combined	g/km	104	109	118	119	114	114/129	120 <sup>6</sup> /132
Tank capacity (usable)	ltr approx.	55	55	55	55	66	66/66	66/66

DIMENSIONS		XF SALOON		XF SPORTBRAKE		XF SALOON		XF SPORTBRAKE
		MANUAL RWD	AUTO RWD	MANUAL RWD	AUTO RWD	MANUAL RWD	AUTO RWD/AWD	AUTO RWD/AWD
Overall length	mm	4,954		4,955		4,954		4,955
Overall width (inc. mirrors)	mm	2,091		2,091		2,091		2,091
Overall width (mirrors folded)	mm	1,987		1,987		1,987		1,987
Overall height	mm	1,457		1,496		1,457		1,496
Wheelbase	mm	2,960		2,960		2,960		2,960
Front track	mm	1,605 (1,597 20" wheels)		1,605 (1,597 20" wheels)		1,605 (1,597 20" wheels)		1,605 (1,597 20" wheels)
Rear track	mm	1,594 (1,586 20" wheels)		1,607 (1,599 20" wheels)		1,595 (1,586 20" wheels)		1,607 (1,599 20" wheels)
Ground clearance	mm	116		116		116		116
Turning circle diameter (kerb-to-kerb)	m	11.61		11.61		11.61		11.61
Boot volume	litres	540		565		540		565

WEIGHT <sup>7</sup>		XF SALOON		XF SPORTBRAKE		XF SALOON		XF SPORTBRAKE
		MANUAL RWD	AUTO RWD	MANUAL RWD	AUTO RWD	MANUAL RWD	AUTO RWD/AWD	AUTO RWD/AWD
Weight from	kg	1,545	1,555	1,660	1,680	1,585	1,595/1,700	1,720/1,770
Gross vehicle weight	kg	2,190	2,190	2,260	2,260	2,250	2,250/2,310	2,320/2,375

ENGINE AVAILABILITY				
	XF SALOON	XF SPORTBRAKE	XF SALOON	XF SPORTBRAKE
Pure	●	●	●	●
Prestige	●	●	●	●
Portfolio	●	●	●	●
R-Sport	●	●	●	●
S	—	—	—	—

● Available — Not Available

Official EU test figures. For comparison purposes only. Real world figures may differ. <sup>2</sup>With 17" wheels. 5.5 l/100km with 18/19/20" wheels. <sup>3</sup>With 17" wheels. 4.3 l/100km with 18/19/20" wheels.

<sup>4</sup>With 17" wheels. 4.8 l/100km with 18/19/20" wheels. <sup>5</sup>With 17" wheels. 113g/km with 18/19/20" wheels. <sup>6</sup>With 17" wheels. 124g/km with 18/19/20" wheels.

Engine availability is market dependent. Please consult your local Jaguar Retailer for details.

		20d 2.0 LITRE 4 CYLINDER TWIN TURBOCHARGED DIESEL		30d 3.0 LITRE V6 6 CYLINDER TWIN TURBOCHARGED DIESEL	
<b>ENGINES</b>					
Capacity	cc	1,999		2,993	
Maximum power	EEC-PS (kW)	240 (177)		300 (221)	
@rev/min	rpm	4,000		4,000	
Maximum torque	EEC-Nm (lb.ft.)	500 (368)		700 (516)	
@rev/min	rpm	1,500		2,000	
<b>PERFORMANCE</b>					
		<b>XF SALOON</b> AUTO RWD/AWD	<b>XF SPORTBRAKE</b> AUTO AWD	<b>XF SALOON</b> AUTO RWD	<b>XF SPORTBRAKE</b> AUTO RWD
0-100 km/h	seconds	6.5/6.5	6.7	6.2	6.6
0-60 mph	seconds	6.3/6.2	6.4	5.8	6.1
Top speed	km/h (mph)	246 (153)/246 (153)	241 (150)	250 (155)	250 (155)
<b>FUEL CONSUMPTION<sup>1</sup></b>					
Urban	l/100km (mpg)	6.5 (43.5)/6.7 (42.2)	7.5 (37.7)	6.6 (42.8)	6.7 (42.2) <sup>8</sup>
Extra Urban	l/100km (mpg)	4.6 (61.4)/4.8 (58.9)	4.8 (58.9)	4.8 (58.9)	5.1 (55.4) <sup>9</sup>
Combined	l/100km (mpg)	5.3 (53.3)/5.5 (51.4)	5.8 (48.7)	5.5 (51.4)	5.7 (49.6) <sup>10</sup>
CO <sub>2</sub> Urban	g/km	170/176	197	171	176 <sup>11</sup>
CO <sub>2</sub> Extra Urban	g/km	121/126	128	125	134 <sup>12</sup>
CO <sub>2</sub> Combined	g/km	139/144	153	144	149 <sup>13</sup>
Tank capacity (usable)	ltr approx.	66/66	66	66	66
<b>DIMENSIONS</b>					
Overall length	mm	4,954	4,955	4,954	4,955
Overall width (inc. mirrors)	mm	2,091	2,091	2,091	2,091
Overall width (mirrors folded)	mm	1,987	1,987	1,987	1,987
Overall height	mm	1,457	1,496	1,457	1,496
Wheelbase	mm	2,960	2,960	2,960	2,960
Front track	mm	1,605 (1,597 20" wheels)	1,605 (1,597 20" wheels)	1,605 (1,597 20" wheels)	1,605 (1,597 20" wheels)
Rear track	mm	1,594 (1,586 20" wheels)	1,607 (1,599 20" wheels)	1,594 (1,586 20" wheels)	1,607 (1,599 20" wheels)
Ground clearance	mm	116	116	110	119
Turning circle diameter (kerb-to-kerb)	m	11.61	11.61	11.61	11.61
Boot volume	litres	540	565	540	565
<b>WEIGHT<sup>7</sup></b>					
Weight from	kg	1,680/1,740	1,805	1,750	1,855
Gross vehicle weight	kg	2,300/2,360	2,395	2,350	2,430
<b>ENGINE AVAILABILITY</b>					
Pure		●	—	—	—
Prestige		●	●	●	—
Portfolio		●	●	●	●
R-Sport		●	●	●	—
S		—	—	—	●

<sup>7</sup>Weights reflect vehicles to standard specifications. Optional extras increase weight. <sup>8</sup>With 18" wheels. 7.0 l/100km (40.4 mpg) with 19/20" wheels. <sup>9</sup>With 18" wheels. 5.2 l/100km (54.3 mpg) with 19/20" wheels. <sup>10</sup>With 18" wheels. 5.9 l/100km (47.9 mpg) with 19/20" wheels. <sup>11</sup>With 18" wheels. 184 g/km with 19/20" wheels. <sup>12</sup>With 18" wheels. 137 g/km with 19/20" wheels. <sup>13</sup>With 18" wheels. 154 g/km with 19/20" wheels.

# TECHNICAL SPECIFICATIONS

 Configure your vehicle at [jaguar.com](http://jaguar.com)

ENGINES		20t 2.0 LITRE 4 CYLINDER TURBOCHARGED PETROL	25t 2.0 LITRE 4 CYLINDER TURBOCHARGED PETROL
Capacity	cc	1,997	1,997
Maximum power	EEC-PS (kW)	200 (147)	250 (184)
@rev/min	rpm	5,500	5,500
Maximum torque	EEC-Nm (lb.ft.)	320 (236)	365 (269)
@rev/min	rpm	1,200-4,500	1,200-4,500

PERFORMANCE		XF SALOON AUTO RWD	XF SALOON AUTO RWD/AWD	XF SPORTBRAKE AUTO RWD
0-100 km/h	seconds	7.5	6.6/6.6	7.1
0-60 mph	seconds	7.1	6.3/6.2	6.7
Top speed	km/h (mph)	235 (146)	244 (152)/237 (147)	241 (150)

FUEL CONSUMPTION <sup>1</sup>				
Urban	l/100km (mpg)	8.4 (33.6)	8.4 (33.6)/8.7 (33.0)	8.5 (33.2)
Extra Urban	l/100km (mpg)	5.8 (48.7)	5.8 (48.7)/6.0 (47.4)	5.9 (47.9)
Combined	l/100km (mpg)	6.8 (41.5)	6.8 (41.5)/6.9 (40.9)	6.8 (41.5)
CO <sub>2</sub> Urban	g/km	192	192/197	192
CO <sub>2</sub> Extra Urban	g/km	132	132/137	134
CO <sub>2</sub> Combined	g/km	154	154/159	155
Tank capacity (usable)	ltr approx.	74	74/74	74

DIMENSIONS				
Overall length	mm	4,954	4,954	4,955
Overall width (inc. mirrors)	mm	2,091	2,091	2,091
Overall width (mirrors folded)	mm	1,987	1,987	1,987
Overall height	mm	1,457	1,457	1,496
Wheelbase	mm	2,960	2,960	2,960
Front track	mm	1,605 (1,597 20" wheels)	1,605 (1,597 20" wheels)	1,605 (1,597 20" wheels)
Rear track	mm	1,594 (1,586 20" wheels)	1,594 (1,586 20" wheels)	1,607 (1,599 20" wheels)
Ground clearance	mm	116	116	116
Turning circle diameter (kerb-to-kerb)	m	11.61	11.61	11.61
Boot volume	litres	540	540	565

WEIGHT <sup>2</sup>				
Weight from	kg	1,635	1,635/1,685	1,705
Gross vehicle weight	kg	2,260	2,260/2,310	2,290

ENGINE AVAILABILITY				
Pure		●	●	●
Prestige		●	●	●
Portfolio		●	●	●
R-Sport		●	●	●
S		—	—	—

● Available — Not Available

Engine availability is market dependent. Please consult your local Jaguar Retailer for details.



ENGINES		30t 2.0 LITRE 4 CYLINDER TURBOCHARGED PETROL	S 3.0 LITRE V6 SUPERCHARGED PETROL
Capacity	cc	1,997	2,995
Maximum power	EEC-PS (kW)	300 (221)	380 (280)
@rev/min	rpm	5,500	6,500
Maximum torque	EEC-Nm (lb.ft.)	400 (295)	450 (332)
@rev/min	rpm	1,500-4,500	4,500
PERFORMANCE		XF SALOON AUTO RWD/AWD	XF SALOON AUTO RWD/AWD
0-100 km/h	seconds	5.9/5.8	5.3/5.3
0-60 mph	seconds	5.6/5.5	5.1/5.0
Top speed	km/h (mph)	250 (155)/250 (155)	250 (155)/250 (155)
FUEL CONSUMPTION <sup>1</sup>			
Urban	l/100km (mpg)	8.6 (32.9)/8.9 (31.7)	11.7 (24.1)/11.9 (23.7)
Extra Urban	l/100km (mpg)	5.7 (49.6)/6.1 (46.3)	6.3 (44.8)/6.7 (42.2)
Combined	l/100km (mpg)	6.8 (41.5)/7.2 (40.0)	8.3 (34.0)/8.6 (32.9)
CO <sub>2</sub> Urban	g/km	194/203	278/282
CO <sub>2</sub> Extra Urban	g/km	130/140	150/160
CO <sub>2</sub> Combined	g/km	153/163	198/204
Tank capacity (usable)	ltr approx.	74/74	74/74
DIMENSIONS			
Overall length	mm	4,954	4,954
Overall width (inc. mirrors)	mm	2,091	2,091
Overall width (mirrors folded)	mm	1,987	1,987
Overall height	mm	1,457	1,457
Wheelbase	mm	2,960	2,960
Front track	mm	1,605 (1,597 20" wheels)	1,605 (1,597 20" wheels)
Rear track	mm	1,594 (1,586 20" wheels)	1,594 (1,586 20" wheels)
Ground clearance	mm	116	116
Turning circle diameter (kerb-to-kerb)	m	11.61	11.61
Boot volume	litres	540	540
WEIGHT <sup>2</sup>			
Weight from	kg	1,660/1,715	1,710/1,760
Gross vehicle weight	kg	2,260/2,330	2,330/2,370
ENGINE AVAILABILITY			
Pure		●	—
Prestige		●	—
Portfolio		●	—
R-Sport		●	—
S		—	●

<sup>1</sup>Official EU test figures. For comparison purposes only. Real world figures may differ. <sup>2</sup>Weights reflect vehicles to standard specifications. Optional extras increase weight.

# XF SALOON DIMENSIONS

**Overall Width** (inc mirrors) 2,091mm

**Overall Width** (mirrors folded) 1,987mm

**Boot Volume** 540 Litres



VEHICLE SHOWN: XF SALOON S IN YULONG WHITE WITH OPTIONAL FEATURES FITTED (MARKET DEPENDENT)

**Turning Circle**  
Kerb-to-kerb 11.61m



\*110mm for 30d 3.0 litre V6 Twin Turbocharged Diesel.  
Dimensions were measured with vehicle at unladen weight.  
(measured by VDA standard test method using 200 x 100 x 50mm blocks).



# XF SPORTBRAKE DIMENSIONS

**Overall Width** (inc mirrors) 2,091mm

**Overall Width** (mirrors folded) 1,987mm

**Boot Volume** 565 Litres

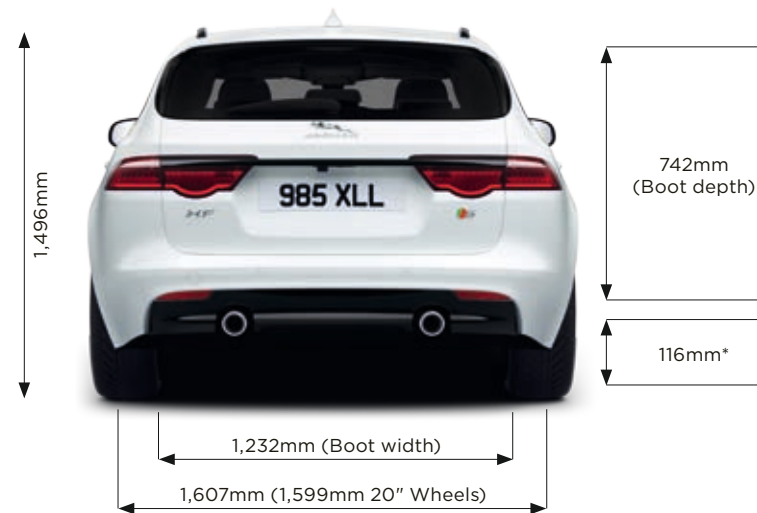

VEHICLE SHOWN: XF SPORTBRAKE S IN YULONG WHITE WITH OPTIONAL FEATURES FITTED (MARKET DEPENDENT)

**Turning Circle**  
Kerb-to-kerb 11.61m



1,144mm  
(Boot length)

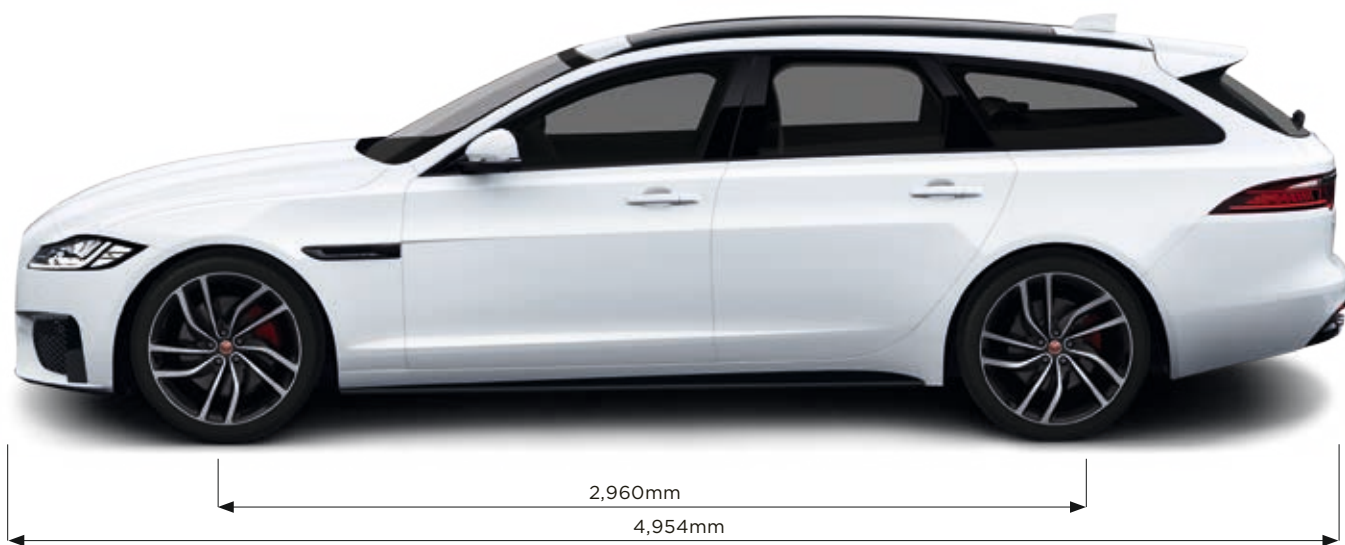

2,960mm

4,954mm

\*119mm for 30d 3.0 litre V6 Twin Turbocharged Diesel.  
Dimensions were measured with vehicle at unladen weight.  
(measured by VDA standard test method using 200 x 100 x 50mm blocks).

## JAGUAR EXPERIENCE

There's no better way to get to know Jaguar than by taking a drive. The Jaguar Experience offers a range of unique opportunities to really find out what it feels like to get the most out of a Jaguar. Our track experiences allow you to push yourself and cars from the incredible Jaguar range to the limit. Jaguar Experience also offers the opportunity to see a Jaguar brought to life during a tour of one of our UK manufacturing facilities.

Find out more by visiting [jaguar.com/experience](http://jaguar.com/experience)



## BEHIND THE SCENES

Our factory tours give you the unique opportunity to experience the whole process of how our cars are brought to life - from the moulding of sheet metal to those intricate final touches. At our state-of-the-art production facilities, you'll get to see how skilled technicians and sophisticated machines work seamlessly together to perfect some of Jaguar's most breathtaking cars.

Find out more at [jaguar.com/experience-jaguar/behind-the-scenes](http://jaguar.com/experience-jaguar/behind-the-scenes)





## DRIVING EXPERIENCES

The opportunity to drive the latest Jaguar cars at their limits, or relive iconic Jaguar history, is rare. Jaguar Driving Experiences offer unique driving adventures you will never forget. Imagine yourself behind the wheel of our highest performing Jaguar models, on a private track, with a Jaguar Experience Instructor at your side. This is the Jaguar Performance Driving Academy.

Find out more at [jaguar.com/experience-jaguar/driving-experiences](http://jaguar.com/experience-jaguar/driving-experiences)



## ICONIC EXPERIENCES

Take your driving to the next level with the Jaguar Land Rover Ice Drive Experience. From 2017, we are offering an adventure in Arjeplog, Sweden, that will test and develop your performance driving skills in extreme conditions. It's a rare chance for owners and enthusiasts to tackle some of the harshest and most challenging tracks on earth, under the skilled guidance of our experts. Our driving instructors are of the highest-calibre and will be with you every step of the way - ready to impart years of driving wisdom. You will dance on ice, glide around some of the most awe-inspiring corners imaginable and realise the true exhilarating potential of Jaguar and Land Rover.

If you'd like to be part of the next adventure, find out more by visiting: [jaguar.com/experience-jaguar/iconic-experiences](http://jaguar.com/experience-jaguar/iconic-experiences)

# THE WORLD OF JAGUAR

Choose an XF and you're joining the exciting World of Jaguar. It makes owning and driving carefree and easy, as well as providing a range of exclusive services and lifestyle products.



## SERVICING

XF has been designed to keep servicing costs to a minimum - for example, the new Ingenium diesel engines can achieve an incredible 34,000km or 2 years\* between services due to intelligent design and advanced oil technology.

## GENUINE PARTS

Jaguar Genuine Parts are designed, tested and manufactured to our uncompromising standards for quality, fit and durability. Each part is engineered specifically for your XF to contribute to optimum performance and to help maximise its lifespan.



## FLEET & BUSINESS

Jaguar is dedicated to being the premium manufacturer of choice for fleets and businesses by providing a highly attractive car range and exemplary customer service. Jaguars are dynamic and distinctive cars that help companies express the unique character and personality of their business. We are committed to providing totally customer-focused aftersales services, which keeps every Jaguar car on the move and in top condition, ensuring that they perform to the highest standard and in the most cost-efficient way for businesses. Visit [jaguar.com/fleet-and-business](http://jaguar.com/fleet-and-business)



#### JAGUAR FINANCIAL SERVICES

Effortless performance and style come as standard with every Jaguar. Jaguar Financial Services makes buying one just as simple and rewarding. New or used, for personal or business use, we have an option that puts you in complete control. Please speak to your local Jaguar Retailer to find out more.



#### JAGUAR ASSISTANCE

Jaguar Assistance provides assistance in motoring emergencies, from immobilisation due to breakdown or accident to minor problems such as punctures. You can rely on our roadside assistance, whatever the situation, wherever you happen to be.

#### LOW INSURANCE

XF's key components are easily accessible for time-efficient service and repair and to minimise scheduled maintenance and repair costs. With a focus on lower repair costs, XF delivers competitive insurance group ratings\*\*. To find out more about the compelling business case for XF, please contact your local Jaguar Retailer.



#### JAGUAR MAGAZINE

This is our own vibrant, cosmopolitan and contemporary magazine. Produced by a team of enthusiastic designers and feature writers, it goes behind the scenes at Jaguar as well as providing insight into the world of luxury, design, style and travel. You can enjoy Jaguar Magazine twice a year completely free of charge for the first three years. Ask your retailer to ensure that you receive your copy.

#### JAGUAR COLLECTION

The latest range from the Jaguar Collection has been crafted with the same design execution and attention to detail that goes into all of our cars. This is evident in our clothing range, premium leather items and luxury travel goods. To celebrate Jaguar's heritage we also have a collection that honours past achievements and features race inspired gift items and apparel. To find out more, visit the online shop at [www.jaguar.com/shop](http://www.jaguar.com/shop)

\*Market and driving style dependent.  
\*\*Manufacturer's estimate.



# GLOSSARY

## A

### ADAPTIVE FULL LED HEADLIGHTS

Adaptive headlights automatically adjust to follow steering inputs, casting light where needed. They will angle the beam when indicating, as well as working in conjunction with Automatic High Beam Assist to prevent your lights from dazzling oncoming traffic.

### ADVANCED PARK ASSIST

Advanced Park Assist offers all the functions of Park Assist (see pg. 52) plus 360° Park Distance Control with virtual object tracking. This gives confidence in confined situations, at speeds up to 16km/h.

### ADAPTIVE SPEED LIMITER

The Adaptive Speed Limiter, when selected, will assist in limiting vehicle speed to the speed limits as recognised by the Traffic Sign Recognition system.

### AUX CONNECTION

Auxiliary (AUX) connections allow for the convenient input of audio signals from personal devices.

## C

### Cd

The Cd value is the drag coefficient of the car. It gives an indication of the vehicle's aerodynamic qualities. The lower the value, the more aerodynamically efficient the vehicle's design.

### CONFIGURABLE INTERIOR MOOD LIGHTING

Configurable Interior Mood Lighting highlights a number of your Jaguar's key functional and styling features and allows adjustment of the ambient light. Choose from a range of ten colours.

### CONNECTIVITY PACKAGE

A connectivity package is a bundle of applications and technologies that enhances your connection with your Jaguar and with the world by giving internet connectivity, optimised in-car applications and remote access to your car.

## D

### DAB RADIO

The DAB (Digital Audio Broadcast) radio system offers clarity of reception, a wide choice of stations and live text information about the station, show and song you are listening to.

### DAMPERS/DAMPING

Dampers absorb forces acting on the suspension for greater ride comfort and control. Dampers are also known as shock absorbers.

### DEAD RECKONING

Dead Reckoning uses sensors to measure vehicle direction, wheel rotation and inclination. These measurements are calibrated up to 40 times per second to ensure accurate placement of the vehicle even when no GPS signal is available.

### DRAG COEFFICIENT

The drag coefficient measures how aerodynamic a car is. See definition of Cd.

## E

### ECO MODE

Eco Mode encourages fuel efficient driving by reducing throttle sensitivity, selecting more economical engine mapping and, on manual vehicles, advising of gearshifts. It also reduces fuel consumption by reducing the energy demands placed on the engine by climate control and audio systems.

## F

### FORWARD ALERT

Should a potential collision be detected Forward Alert gives an audible warning and a visual warning in the instrument cluster.

### FOUR-ZONE CLIMATE CONTROL

Four-zone Climate Control that can be optimised for individual occupants.

### 12.3" FULL DIGITAL INSTRUMENT PANEL

The 12.3" Full Digital Instrument Panel is a TFT (Thin Film Transistor) screen that replaces the traditional instrument cluster. It displays a wide range of key driving information. Four graphical themes and a 3D Map View are available.

## G

### GPS

The Global Positioning System (GPS) uses satellites to determine the car's position. By cross-referencing this with road maps stored in its memory, the navigation system provides route guidance and tracks the car's location.

## I

### INGENIUM ENGINES

Ingenium engines are manufactured in the UK at Jaguar Land Rover's state-of-the-art Engine Manufacturing Centre in the West Midlands. The aluminium engines feature lightweight construction, with stiff cylinder blocks and decoupled injectors, which ensure low levels of vibration and noise intrusion, further enhancing the driver experience. A series of advanced technologies reduce internal friction, improve refinement and enhance overall performance. In addition, Selective Catalytic Reduction and a new low-pressure exhaust gas recirculation system significantly reduce both CO<sub>2</sub> and NOx emissions on diesel engines.

### INTERIOR MOOD LIGHTING

Interior mood lighting highlights many of the cabin's key features and design details in a relaxing soft Phosphor Blue glow.

### INTELLIGENT STOP/START

Stop/Start is a technology that stops the engine when it is not needed, improving the fuel economy and reducing the car's CO<sub>2</sub> emissions. The engine will restart as soon as the driver's foot comes off the brake pedal. The engine will be operating at full capacity before the driver's foot has touched the accelerator pedal.

## J

### JAGUAR SIGNATURE 'J' BLADE DAYTIME RUNNING LIGHTS

'J' blade Daytime Running Lights are separate LED running lights, in a distinctive 'J' shape, built into the headlights. They emphasise Jaguar's striking on road style.

### JAGUARDRIVE CONTROL

Interacts with the Dynamic Stability Control system, engine and transmission management systems to alter the characteristics of the engine mapping, gearshifts and brakes. It offers different modes designed to optimise the vehicle's response to particular driving conditions and styles.

### JAGUARDRIVE SELECTOR

The JaguarDrive Selector rises from the centre console on start up. It is a rotary shifter used with automatic transmissions that allows you to quickly shift between drive modes.

## L

### LED HEADLIGHTS WITH LED 'J' BLADE DAYTIME RUNNING LIGHTS

Multiple powerful LED emitters give a clearer light in low light conditions. Further complemented with LED 'J' blade Daytime Running Lights incorporating LED direction indicators. These lights also integrate Jaguar's Adaptive Lighting and Auto High Beam Assist systems.



## M

### MHL CONNECTION

A Mobile High-Definition Link (MHL) enables connection between a personal device and the InControl infotainment system. It is designed for seamless transfer of audio-visual data.

### 10.2" MULTI-TOUCH DISPLAY

The multi-touch functionality of Touch Pro's 10.2" Display allows the screen to recognise multiple points of contact. This provides direct control of the system's features in a more natural, intuitive way, enabling gestures such as pinch and zoom.

## R

### RAIN ICE SNOW MODE

By selecting Rain Ice Snow Mode, the system automatically dampens acceleration and applies more gradual torque for improved traction in slippery conditions.

## S

### SATELLITE VIEW

Satellite View allows you to view satellite imagery as an optional view mode for the navigation system.

### SECURE TRACKER

Secure Tracker provides stolen vehicle tracking. Tracking technology alerts you to an attempted theft and shares your vehicle's location with the authorities for a timely recovery.

### SD CARD

A Secure Digital (SD) Card is a flash memory card used for storing large amounts of data in a compact form.

### SOLID STATE DRIVE

Solid State Drives are storage devices with no moving parts designed for rapid retrieval of large quantities of data.

## X

### XENON HEADLIGHTS

Bi-function Xenon headlights offer improved illumination and feature LED 'J' blade Daytime Running Lights for a striking on road style.

## IMPORTANT NOTICE

Jaguar Land Rover Limited is constantly seeking ways to improve the specification, design and production of its vehicles and alterations take place continually. While every effort is made to produce up-to-date literature, this brochure should not be regarded as an infallible guide to current specifications, nor does it constitute an offer for the sale of any particular vehicle. Vehicles shown in this brochure are from the Jaguar Global range. Specifications, options and availability will vary between markets and should be verified with your local Jaguar Retailer. Distributors and retailers are not agents of Jaguar Land Rover Limited by any express or implied undertaking or representation. Comparisons are based on manufacturer's own data and testing prior to publication.

## COLOURS

Print and online colours are representative only.

## ENVIRONMENTAL INNOVATION AT JAGUAR

Jaguar is committed to reducing dependency on fossil fuels, using fewer natural resources and creating less waste as part of our approach to responsible and sustainable business development, called Environmental Innovation.

Our innovative use of lightweight aluminium (featured in the F-PACE, XF, XE, XJ and F-TYPE) is helping to improve fuel consumption and lower tailpipe CO<sub>2</sub> emissions, as well as delivering other handling and performance benefits to these vehicles.

At the same time, our smart management of resources enables scrap aluminium reclaimed from our stamping process to be segregated and recycled to create the same quality of aluminium sheet with up to 50% recycled content. Compared to using virgin aluminium, this closed-loop recycling system also reduces CO<sub>2</sub> emissions during the manufacturing process.

As a whole, Jaguar Land Rover has reduced its European fleet average tailpipe emissions by 25% versus 2007 and operational CO<sub>2</sub> emissions per vehicle by 30.5%\*. Our manufacturing facilities are all certified to ISO14001 and we have cut the amount of manufacturing waste to landfill per vehicle by 75%\* and reduced our water consumption per vehicle by 34%\*. \*Versus 2007.

As part of our journey to Carbon Neutral Manufacturing by 2020, we offset 100% of (currently unavoidable) operational CO<sub>2</sub> emissions by investing in projects that reduce the equivalent amount of CO<sub>2</sub> emissions in other ways, providing social and humanitarian benefits at the same time. For example, our award winning Lifestraw 'carbon for water' emissions reduction project has prevented the release of 968,000 tonnes of CO<sub>2</sub> (since it began in 2013) and improved the lives of 2.4 million people in Kenya.

Taking into account the company's global sales growth and increased investment in more efficient operating facilities, we are proud of the progress we have made against our 2020 Environmental Innovation targets to date. Our achievements have also been recognised externally: In 2013 the Company was recognised as the UK's Responsible Business of the Year by leading CR index, Business in the Community and in 2014 we were awarded the Queen's Award for Enterprise in Sustainable Development.

Looking forward, we have developed a 2020 vision for sustainable business growth that focuses on continued improvements in operating & tailpipe CO<sub>2</sub> emissions, carbon neutral manufacturing and zero waste. Jaguar Land Rover also aims to improve the lives of 12 million people by 2020 as part of its global Corporate Social Responsibility programme.

Meridian is the registered trademark of Meridian Audio Limited.

AdBlue® is the registered trademark of the Verband der Automobilindustrie e. V. (VDA).

The Bluetooth® word mark and logos are owned by the Bluetooth SIG, Inc. and any use of such marks by Jaguar Land Rover Limited is under licence.

iPod, iPod touch and iPad are trademarks of Apple Inc., registered in the US and other countries.

**VEHICLES SHOWN FRONT COVER: XF SPORTBRAKE S IN YULONG WHITE AND XF SALOON R-SPORT IN CORRIS GREY WITH OPTIONAL FEATURES FITTED (MARKET DEPENDENT)**

**VEHICLES SHOWN BACK COVER: XF SPORTBRAKE S IN YULONG WHITE AND XF SALOON R-SPORT IN CORRIS GREY WITH OPTIONAL FEATURES FITTED (MARKET DEPENDENT)**

Jaguar Land Rover Limited  
Registered Office: Abbey Road, Whitley,  
Coventry, CV3 4LF, United Kingdom  
Registered in England Number: 1672070  
jaguar.com

